

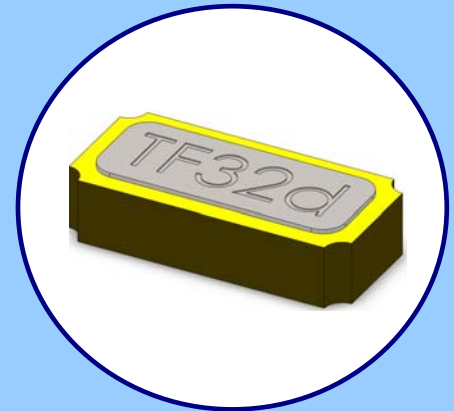

FEATURES

- **32.7680 kHz Frequency Reference**
- **Package Size 3.2mm x 1.5mm**
- **Tuning Fork Crystal Design**
- **Hermetic Ceramic Package**
- Frequency Tolerance, ± 20 ppm Standard
[± 10 ppm, ± 30 ppm and ± 50 ppm available]
- Frequency Temperature Coefficient, -0.030 ppm/ $^{\circ}\text{C}^2$
- Operating Temperature, -40°C to $+85^{\circ}\text{C}$ Standard
- Tape & Reel Packaging
- **RoHS/Green Compliant (6/6)**



APPLICATIONS

The TF32 crystal series is ideal for use in a wide range of communication equipment, measurement equipment, industrial applications, automotive electronics, wireless communications, PDAs, mobile phones and notebooks.

ORDERING INFORMATION

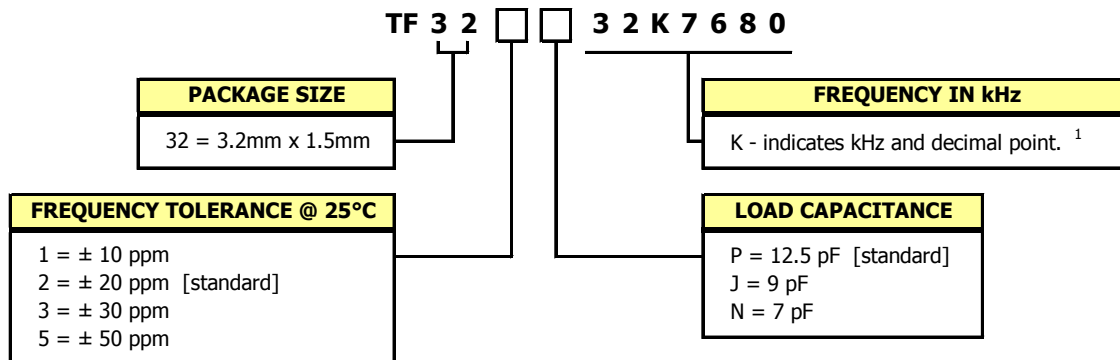

Example Part Numbers:
TF322P32K7680
TF322J32K7680

1] Frequency is recorded with two leading digits before the 'K' and 4 significant digits after the 'K' (including zeros).

**Not all performance combinations and frequencies may be available.
Contact your local CTS Representative or CTS Customer Service for availability.**

ELECTRICAL CHARACTERISTICS

	PARAMETER	SYMBOL	CONDITIONS	MIN	TYP	MAX	UNIT
ELECTRICAL PARAMETERS	Frequency	f_0			32.7680		kHz
	Operating Mode	-		Flexural Mode [Tuning Fork]			-
	Frequency Tolerance @ +25°C *	$\Delta f/f_0$		-	20	-	± ppm
	Frequency Temperature Coefficient	$\Delta f/f_M$		-0.030 ±0.01ppm/°C ²			-
	Frequency Stability			See Figure 1			
	Operating Temperature Range	T_A		-40	-	+85	°C
	Turnover Temperature	T_M	±5°C	-	+25	-	°C
	Load Capacitance *	C_L	Standard	-	12.5	-	pF
	Aging	$\Delta f/f_0$	@+25°C, 1st year	-	-	3.0	± ppm
	Drive Level	DL		-	0.1	0.5	µW
	Shunt Capacitance	C_0	@1 MHz	-	-	7.0	pF
	Motional Capacitance	C_1		-	5.0	-	fF
	Series Resistance	R_1		-	-	70	k Ohms
	Insulation Resistance	R_i	+100Vdc ±15Vdc	500	-	-	M Ohms
	Storage Temperature Range	T_{STR}		-55	-	+125	°C

* See Ordering Information for available options.

FIGURE 1

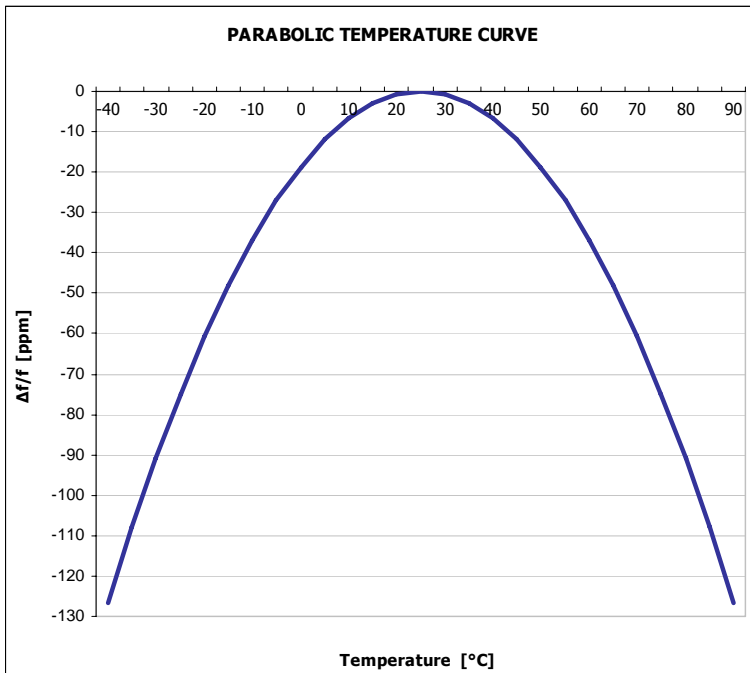

Frequency stability [ppm] is determined using parabolic curve, $\Delta f = \text{Temperature Coefficient}(T_A - T_M)^2$.

Ex. Find frequency stability at $T_A = 45^\circ\text{C}$
 $\Delta f = -0.030(45-25)^2$
 $\Delta f = -0.030(20)^2$
 $\Delta f = -12.0 \text{ ppm}$

PACKAGING INFORMATION

Per standard EIA-418. Device quantity is 3,000 pieces per 180mm reel

DIMENSIONS IN MILLIMETERS

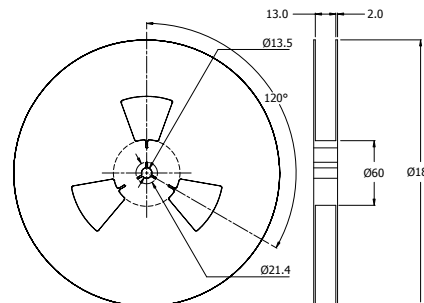
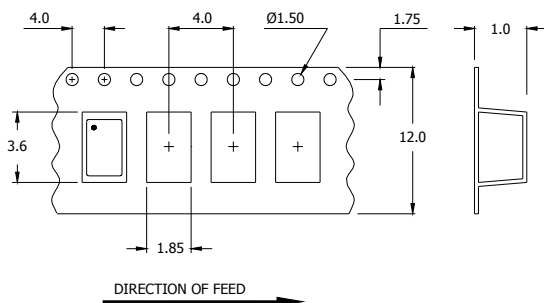

MECHANICAL SPECIFICATIONS

TF32 PACKAGE DRAWING

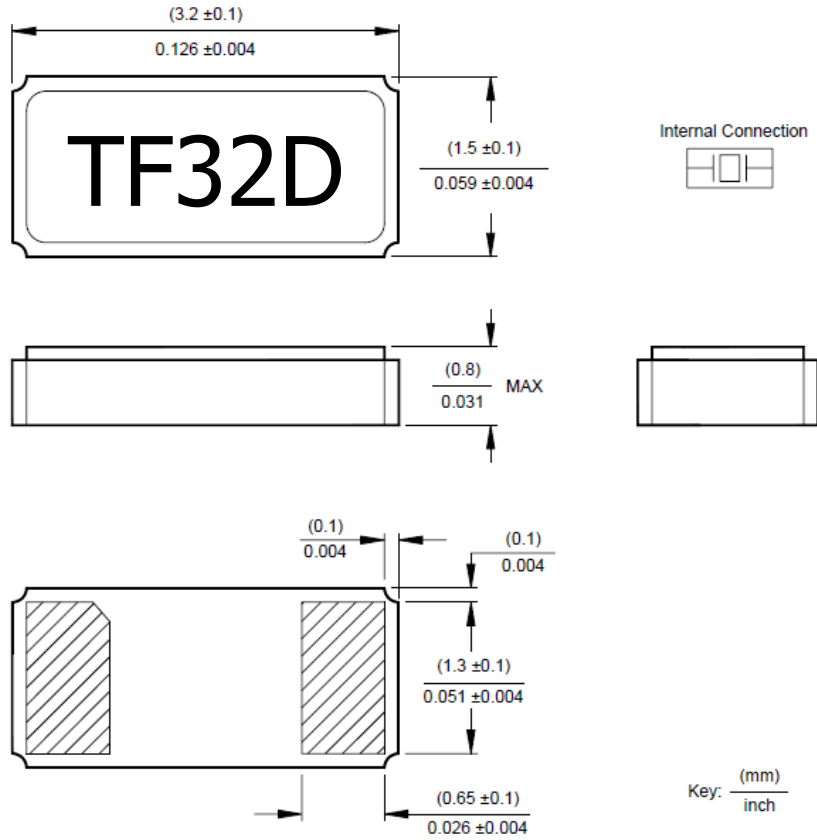

MARKING INFORMATION

1. TF32 - CTS Model Series.
2. D - Date code. See Table I for codes.

TABLE I - DATE CODE

YEAR		MONTH					JAN	FEB	MAR	APR	MAY	JUN	JUL	AUG	SEP	OCT	NOV	DEC
		2001	2005	2009	2013	2017	A	B	C	D	E	F	G	H	J	K	L	M
2002	2006	2010	2014	2018	N	P	Q	R	S	T	U	V	W	X	Y	Z		
2003	2007	2011	2015	2019	a	b	c	d	e	f	g	h	j	k	l	m		
2004	2008	2012	2016	2020	n	p	q	r	s	t	u	v	w	x	y	z		

SUGGESTED SOLDER PAD GEOMETRY

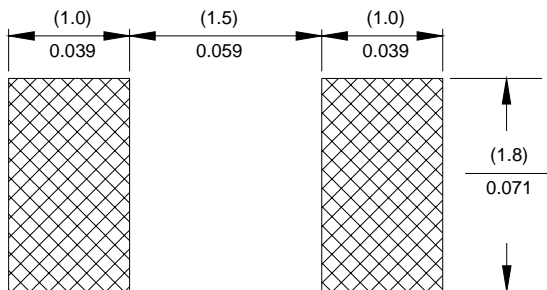

Key: $\frac{\text{(mm)}}{\text{inch}}$

NOTES

1. Complete CTS part number, frequency value, date code and manufacturing site code information must appear on reel and carton labels.
2. Termination pads (e4); barrier plating is nickel [Ni] with gold [Au] flash plate.
3. Reflow conditions per JEDEC J-STD-020; 260°C maximum, 20 seconds.