

# **Cree LED Module LMR2 with Cree TrueWhite® Technology**

**A fast, proven way to realize the promise of LED Lighting**

## **Data Sheet**

Cree LED Modules provide a simple solution for lighting designers and manufacturers to adopt best in class LED lighting from Cree. The LMR series continues Cree's history of innovation in LEDs for lighting applications and provides a comprehensive solution including Cree's patented Cree TrueWhite Technology to achieve an industry-leading combination of light quality and efficacy. This versatile LED lighting module allows design flexibility with the beautiful color and efficacy of Cree TrueWhite Technology.

The Cree LED Module LMR2 with Cree TrueWhite Technology is the ideal choice for lighting applications where high CRI and efficacy are required, such as restaurants, retail and hospitality lighting. The compact module form factor is a benefit to lighting manufacturers seeking a simple solution to adopt LED lighting or cost-effectively expand their existing LED-lighting product portfolio.

## **FEATURES**

- Cree TrueWhite Technology
- Comprehensive solution with driver electronics, optics and core thermals
- 650 lm @ 2700, 3000, 3500, 4000 K CCT
- Supports dimming to 5%
- Designed to last at least 35,000 hours at L70
- Versatile form factor for small-aperture designs
- Cree IES LM-80 data in support of U. S. DOE ENERGY STAR® qualification
- The LMR2 (120 V) is UL-recognized and California Title 24-compliant, and the LMR2 (230 V) complies with multiple international standards (pending)

Cree TrueWhite technology:

- A better way to generate white light that utilizes a patented mixture of unsaturated yellow and saturated red LEDs.
- Proprietary optical system utilizes a unique combination of reflective and refractive optical components to achieve a uniform, comfortable appearance. Pixelation and direct view of LEDs is eliminated.
- Technology benefit - high CRI and efficacy allows customers to avoid having to make tradeoffs between energy efficiency and light quality as compared to other lighting alternatives.
- Marketing benefit - Cree logo on lens enables brand marketing value on final design.



## Characteristics

The following table provides several base order codes for the Cree LED module LMR2, as well as a description of the order-code nomenclature.

| CCT*   | Nominal Luminous Flux (lm) | CRI | Input Power | Input Voltage/Freq | Power Factor | Order Code               |
|--------|----------------------------|-----|-------------|--------------------|--------------|--------------------------|
| 4000 K | 650                        | 90  | 12 W        | 120 V/60 Hz        | >.80         | LMR020-0650-40F9-10100TW |
|        |                            |     |             | 230 V/50 Hz        | >.90         | LMR020-0650-40F9-20100TW |
| 3500 K | 650                        | 90  | 12 W        | 120 V/60 Hz        | >.80         | LMR020-0650-35F9-10100TW |
|        |                            |     |             | 230 V/50 Hz        | >.90         | LMR020-0650-35F9-20100TW |
| 3000 K | 650                        | 90  | 12 W        | 120 V/60 Hz        | >.80         | LMR020-0650-30F9-10100TW |
|        |                            |     |             | 230 V/50 Hz        | >.90         | LMR020-0650-30F9-20100TW |
| 2700 K | 650                        | 90  | 12 W        | 120 V/60 Hz        | >.80         | LMR020-0650-27F9-10100TW |
|        |                            |     |             | 230 V/50 Hz        | >.90         | LMR020-0650-27F9-20100TW |

\* Refer to section below on chromaticity for more details

Note: Cree maintains a tolerance of +/- 7% on flux and power measurements

## Form Factor

Form factor and measurements are shown below and additional details are also available by downloading the STEP file from [www.cree.com/modules](http://www.cree.com/modules). The Cree LED module LMR2 is constructed with a durable cast-aluminum casing and comes complete with an integrated thermal management system. This system conducts heat away from LEDs and transfers it to the case, providing luminaire designers with the flexibility to further optimize their thermal design. A custom fit heat sink is also available and can be ordered separately (part number LMR020-HS02-0000-0000001).

The weight of the LMR2 module is approximately 274 grams and 125 grams for the heat sink.

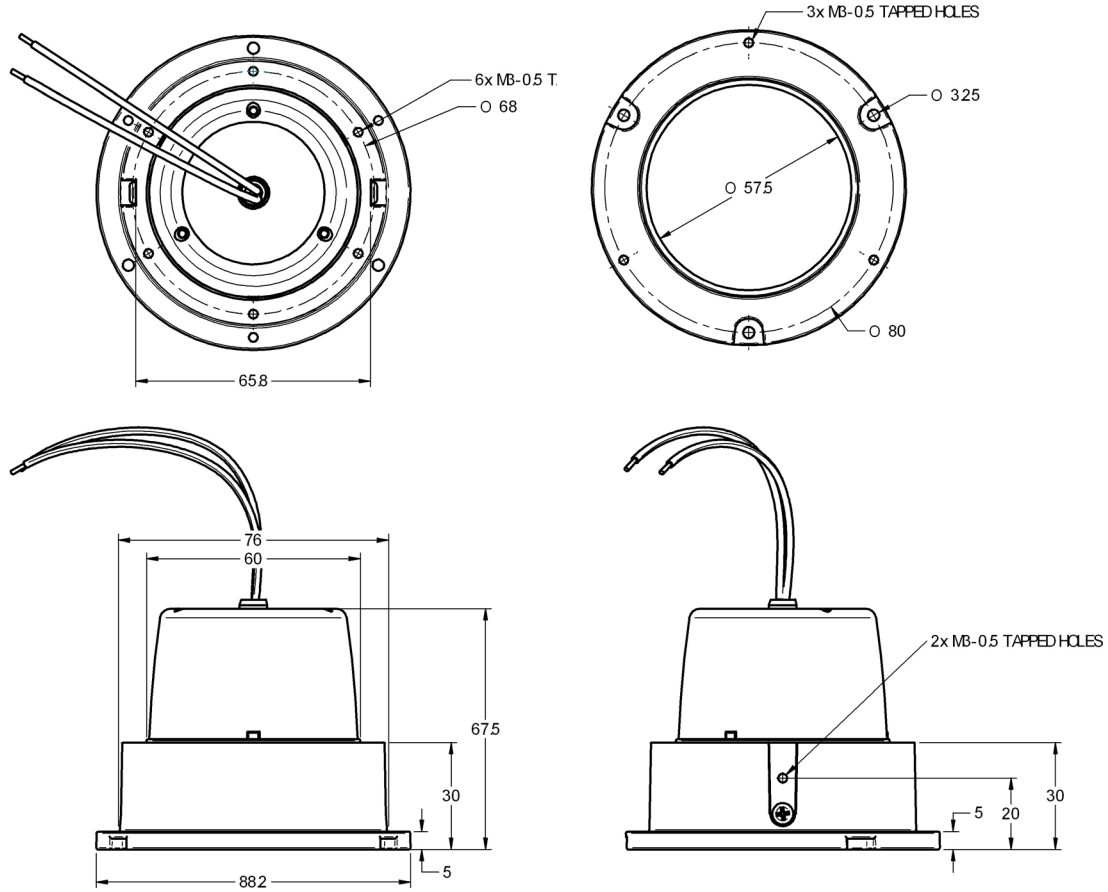

Operating temperature of the Cree LED Module LMR2 is between 0°C and 50°C. The lifetime and performance estimates described in this document apply only if the product's Thermal Management Guidelines (below) are adhered to and no modifications are made except as described in this document.

The LED module is flexible; use of the optional heat sink depends on the design requirements. Secondary optics may be added to the module diffuser and lens but will likely reduce the light output and could also alter the color characteristics of the final luminaire design.

## Thermal Management Guidelines

The Cree LED module LMR2 is designed to perform in a variety of environments; however, the LED module lifetime is highly dependent upon the operating temperature. To achieve lifetime and performance estimates, and maintain the warranty, the final design cannot exceed 70 degrees Celsius at thermal equilibrium, based on the thermocouple (Tc) location shown in the Form Factor section above.

## Photometry

The following photometry results are based on independent testing.

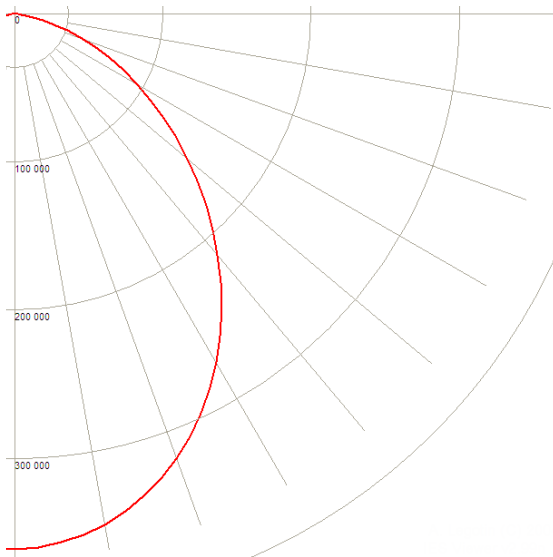

**Intensity (Candlepower )  
 Summary**

| Angle | Mean CP |
|-------|---------|
| 0     | 365.33  |
| 5     | 362.08  |
| 15    | 340.77  |
| 25    | 300.22  |
| 35    | 245.59  |
| 45    | 184.32  |
| 55    | 124.33  |
| 65    | 71.01   |
| 75    | 37.00   |
| 85    | 27.62   |
| 90    | 0.10    |

**Zonal Lumens Summary**

| Zone | Lumens | %Lamp | %Fixt |
|------|--------|-------|-------|
| 0-30 | 242.9  | 35%   | 35%   |
| 0-40 | 381.5  | 55%   | 55%   |
| 0-60 | 607.6  | 87%   | 87%   |
| 0-90 | 700    | 100%  | 100%  |

## Chromaticity

The Cree LED Module LMR2 provides high color consistency around the specified color temperature. Individual LEDs are tested and matched in order to meet the designed chromaticity specification within a 4-step MacAdam ellipse centered around the Black Body line at each color temperature (2700 K, 3000 K, 3500 K, 4000 K CCT)

| Color Temp Code | CCT   | x       | y       |
|-----------------|-------|---------|---------|
| 27F             | 2700K | .458587 | .420302 |
|                 |       | .468390 | .416346 |
|                 |       | .456921 | .400031 |
|                 |       | .447255 | .403738 |

## Order Codes

