

QSFP28/QSFP+ 100G/400G LOOPBACK MODULE

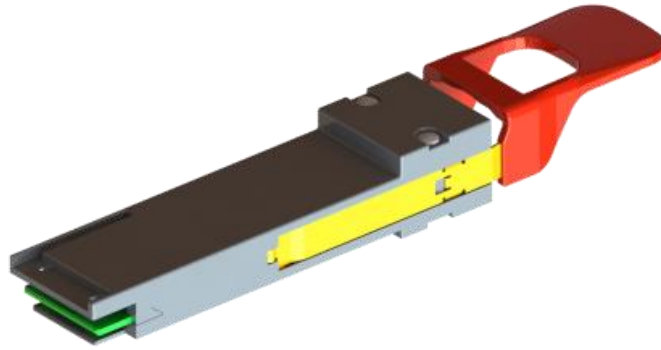

0- Watt

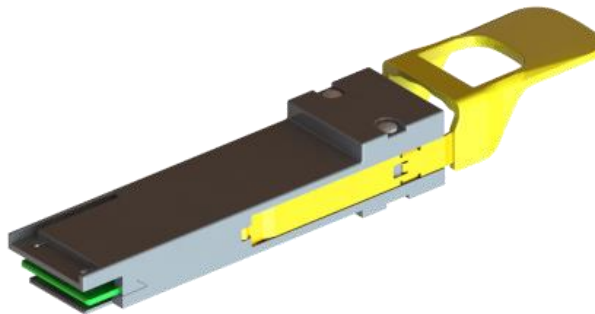

3.5-Watt

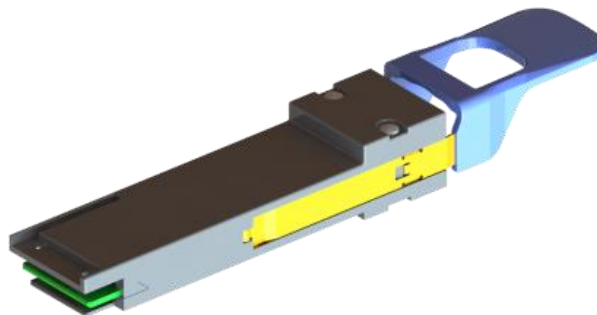

7-Watt

FEATURES

- ◆ Industry's highest rated mating cycles for 2000 and above
- ◆ Built-in surge current mitigation technology
- ◆ Built-in programmable power dissipation up to 7 W
- ◆ Operating temperature: -40°C to 85°C
- ◆ +3.3V power supply
- ◆ Supports 10G/25G data rates
- ◆ 2-wire interface for integrated Digital Diagnostic Monitoring
- ◆ Signal integrity performance meets IEEE 802.3ba, 802.3bj standards respectively
- ◆ Custom EEPROM available
- ◆ A multi-color LED indicator for high/low power modes
- ◆ Hot-pluggable
- ◆ RoHS 2.0 compliant

REFERENCES

- [1] SFF-8665, QSFP+ 28 Gb/s 4X Pluggable Transceiver Solution (QSFP28), Rev 1.8
- [2] SFF-8636, Management Interface for Cabled Environments, Rev 2.9
- [3] SFF-8661, Mechanical requirements specification
- [4] SFF-8679, QSFP28 4X Base Electrical Specification, Rev 1.7
- [5] SFF-8024, SFF Cross Reference to Industry Products, Rev 4.4

Description

Designed and engineered to accommodate customers high usage 2000 cycles at -40°C to 85°C, the loopback module series are the most reliable products in the market to enable the quickest customers systems production and deployment. Software defined multiple power consumption may emulate the optical module power, and the embedded insertion loss characteristics emulates the real-world cabling for 40G/100G Ethernet/Infiniband/FC. The built-in surge current mitigation technology mitigates the DUT risks from being damaged. The broad operating temperature range accommodates the enterprise, datacom and telecom applications. The loopback module may be used for ports testing, field deployment testing and equipment troubleshooting.

ColorChip SmartLoop for QSFP 100G/40G

Mechanical Dimensions

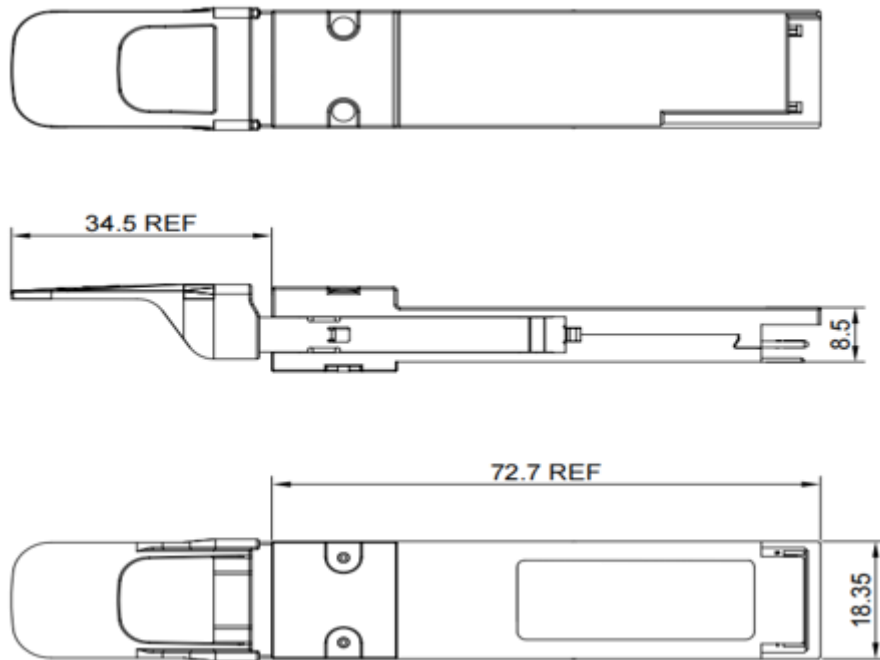

Mechanical Drawing

Ordering Information

Model Number	Part Number	Product Description
T-25-Q-LB-070	1060100032070	QSFP28 100G/40G LOOPBACK ,7W, BLUE PULLTAB
T-25-Q-LB-035	1060100032035	QSFP28 100G/40G LOOPBACK ,3.5W, YELLOW PULLTAB
T-25-Q-LB-000	1060100032000	QSFP28 100G/40G LOOPBACK ,0W, RED PULLTAB