

4305 - 4371

500 ml UV safe Packo



Product part	Product code	Materials
Packo container	4305	HDPE
Packo lid	4371	HDPE
Flat gasket	/	TPE

Capacity	Milliliters	US Fluid ounces
Brimful	555	21.9
When closed	505	17.1

Hazardous material information	
Hazardous material type	Solids
Packaging group	I – II – III
UN marking	1H2/X0.7/Y1.0/Z1.5/S/--/NL/CURTEC-110503
Maximum gross mass (kg)	X=0.7 Y=1.0 Z=1.5

Weight	Grams	Ounces
Packo container	35	1.24
Packo lid	26	0.92
Total	61	2.16

Weight tolerance

All products have a tolerance of $\pm 4\%$ of the initial weight mentioned on this data sheet

Dimensional tolerance (mm) according to DIN16742-TG7

Over	1	>3	>6	>10	>18	>30	>50	>80	>120	>180	>250	>315	>400	>500	>630	>800
up to	3	6	10	18	30	50	80	120	180	250	315	400	500	630	800	1000
NW (\pm)	0.20	0.29	0.35	0.42	0.50	0.60	0.90	1.25	1.45	1.60	1.80	2.60	3.50	4.00	4.50	5.00

Standard color(s)	Color code	PMS references
Packo container	Black 101	/
Packo lid	Black 101	/

Product identification	Container	Lid
Manufacturer ID	Bottom	--
Product code	Bottom	Inside
Recycle logo / Material type	Bottom	Inside
Date clock	Bottom	Inside
UN-mark	Bottom	--
Food logo	Bottom	--
Material track clock	Bottom	Inside
CFR49-mark	Bottom	--

Other information

The container can be opened and closed with just a quarter-turn
Packo consists of a container and a lid with tear-off tamper evident seal
Maximum filling temperature is 70°C/ 158°F
Contents must have cooled to 30°C/ 86°F before containers can be closed and stacked
DoC available on request
UN certificate available on request
MVTR declaration available on request
Watertightness declaration available on request
User manual available on request
Other versions optional

DISCLAIMER

CurTec manufactures packaging material for a wide range of purposes. This declaration is restricted to the packaging material as it leaves the production facility. CurTec has neither control over final end use of the product nor over processing conditions. It is therefore the responsibility of the end user to check compliance with the relevant regulations and to validate material performance in the end application through proper end use testing.

© 2020 Property of CurTec International B.V. All rights explicitly reserved, it is not allowed to copy or communicate to other parties without written consent of CurTec.

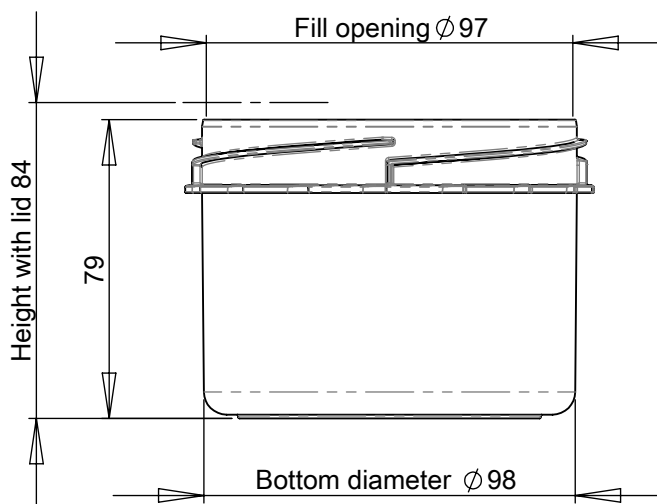
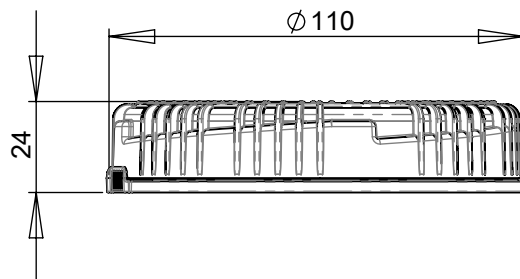

Title 4305 – 4371 Packo 500 ml

Revision	Rev. Date	Units
F	12-12-2019	mm



This document is property of CurTec Nederland B.V.
and may not be copied or communicated without written consent.
All Rights Reserved

