



## SPECIFICATION FOR APPROVAL

Customer : STD

Description : DC FAN

Customer Part No. \_\_\_\_\_

REV. : \_\_\_\_\_

Delta Model No. : THD0812VE-00

REV. : 00

Sample Issue No. : \_\_\_\_\_

Sample Issue Date : OCT.26 2020

PLEASE SEND ONE COPY OF THIS SPECIFICATION BACK AFTER YOU SIGNED APPROVAL FOR PRODUCTION PRE-ARRANGMENT.

APPROVED BY:

DATE :

DELTA ELECTRONICS, INC.  
TAOYUAN PLANT  
252, SHANGYING ROAD, GUIZHAN INDUSTRIAL ZONE,  
TAOYUAN CITY 33341, TAIWAN  
TEL:886-(0)3-3591968  
FAX:886-(0)3-3591991



DELTA ELECTRONICS, INC.  
252, SHANGYING ROAD, GUISHAN INDUSTRIAL ZONE,  
TAOYUAN CITY 33341, TAIWAN

TEL : 886-(0)3-3591968  
FAX : 886-(0)3-3591991

## STATEMENT OF DEVIATION

NONE

DESCRIPTION:

DELTA ELECTRONICS, INC.  
252, SHANGYING ROAD, GUISHAN INDUSTRIAL ZONE,  
TAOYUAN CITY 33341, TAIWAN

TEL : 886-(0)3-3591968  
FAX : 886-(0)3-3591991

## Specification For Approval

Customer : STD

Description : DC FAN

Customer P/N :

rev. :

Delta model no. : THD0812VE-00

Delta Safety Model No.: THD0812VE-00

Sample revision. : 00

Issue no.:

Sample issue date : OCT.26 2020

Quantity :

### 1. SCOPE:

THIS SPECIFICATION DEFINES THE ELECTRICAL AND MECHANICAL CHARACTERISTICS OF THE DC BRUSHLESS AXIAL FLOW FAN.

### 2. CHARACTERS:

| ITEM                                       | DESCRIPTION   |
|--|---|
| RATED VOLTAGE                              | 12 VDC  |
| OPERATION VOLTAGE                          | 10.8 - 13.2 VDC   |
| INPUT CURRENT (AVG.)                       | 15.0 (MAX. 17.5) A<br>SAFETY CURRENT ON LABEL: 21.0A                          |
| INPUT POWER (AVG.)                         | 180.0 (MAX. 210.0) W  |
| F00 SPEED                                  | FRONT : 15000 ±10% / REAR : 15000 ±10% RPM                                    |
| ACTUAL SPEED                               | FRONT : 15500 ±10% / REAR : 15500 ±10% RPM                                    |
| MAX. AIR FLOW<br>(AT ZERO STATIC PRESSURE) | 5.522 (MIN. 4.970) M <sup>3</sup> /MIN.<br>195.00 (MIN. 175.50) CFM           |
| MAX. AIR PRESSURE<br>(AT ZERO AIRFLOW)     | 190.00 (MIN. 153.90) mmH2O<br>7.48 (MIN. 6.059) inchH2O                       |
| ACOUSTICAL NOISE (AVG.)                    | 78.5 (MAX. 82.5) dB-A   |
| INSULATION TYPE                            | UL: CLASS A   |
| INSULATION STRENGTH                        | 10 MEG OHM MIN. AT 500 VDC<br>(BETWEEN FRAME AND (+) TERMINAL)                |
| DIELECTRIC STRENGTH                        | 5 mA MAX. AT 500 VAC 50/60 Hz ONE MINUTE,<br>(BETWEEN FRAME AND (+) TERMINAL) |

(continued)

PART NO:

DELTA MODEL: THD0812VE-00

|   |  |
|---|--|
| LIFE EXPECTANCE (L10)<br>(AT LABEL VOLTAGE) | 70,000 HOURS CONTINUOUS OPERATION AT 40 °<br>C WITH 15 ~ 65 %RH. |
| ROTATION                                    | TWO FANS ROTATE IN COUNTER DIRECTIONS.                           |
| LOCKED CURRENT SHUT DOWN                    | THE CURRENT WILL SHUT DOWN, WHEN ROTOR<br>LOCKED AND FIXED.      |

NOTES:

1. ALL READINGS ARE MEASURED AFTER STABLY WARMING UP THROUGH 10 MINUTES.
2. STANDARD AIR PROPERTY IS AIR AT (Td) 25°C TEMPERATURE, (RH) 65% RELATIVE HUMIDITY , AND (Pb) 760 mmHg BAROMETRIC PRESSURE.
3. THE VALUES WRITTEN IN PARENS , ( ), ARE LIMITED SPEC.
4. THE CHARACTERS SHOWED IN PAGE 1 IS THE CONDITION OF BOTH FANS RUN.
5. ACOUSTICAL NOISE MEASURING CONDITION:

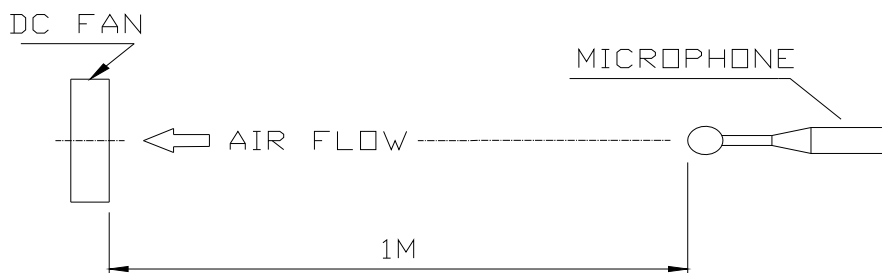

NOISE IS MEASURED AT RATED VOLTAGE IN FREE AIR IN ANECHOIC CHAMBER WITH B & K SOUND LEVEL METER WITH MICROPHONE AT A DISTANCE OF ONE METER FROM THE FAN INTAKE.

---

PART NO:

---

DELTA MODEL: THD0812VE-00

---

3. MECHANICAL:

- 3-1. DIMENSIONS----- SEE DIMENSIONS DRAWING
- 3-2. FRAME----- PLASTIC UL: 94V-0(RECYCLED MATERIAL NOT ALLOWED)
- 3-3. IMPELLE-----PLASTIC UL: 94V-0(RECYCLED MATERIAL NOT ALLOWED)
- 3-4. BEARING SYSTEM----- FOUR BALL BEARINGS
- 3-5. WEIGHT----- 410 GRAMS(REF.)
- 3-5-1. IMPELLER WEIGHT-----77 GRAMS(REF.)
- 3-6. INGRESS PROTECTION RATE-----IP51
- 3-7. CORROSION PROTECTION-----ADD GLUE ON PAD OF PCBA

4. ENVIRONMENTAL:

- 4-1. OPERATING TEMPERATURE----- -10 TO +70 DEGREE C
- 4-2. STORAGE TEMPERATURE----- -40 TO +75 DEGREE C
- 4-3. OPERATING HUMIDITY----- 5 TO 90 % RH
- 4-4. STORAGE HUMIDITY----- 5 TO 95 % RH

5. PROTECTION:

- 5-1. LOCKED ROTOR PROTECTION  
IMPEDANCE OF MOTOR WINDING PROTECTS MOTOR FROM FIRE IN  
96 HOURS OF LOCKED ROTOR CONDITION AT THE RATED VOLTAGE.
- 5-2. POLARITY PROTECTION  
BE CAPABLE OF WITHSTANDING IF REVERSE CONNECTION FOR  
POSITIVE AND NEGATIVE LEADS.

6. RE OZONE DEPLETING SUBSTANCES:

- 6-1. NO CONTAINING PBBs, PBBOs, CFCs, PBBEs, PBDPEs AND HCFCs.

7. PRODUCTION LOCATION

- 7-1. PRODUCTS WILL BE PRODUCED IN CHINA OR THAILAND.

PART NO:

DELTA MODEL: THD0812VE-00

8. P & Q CURVE:

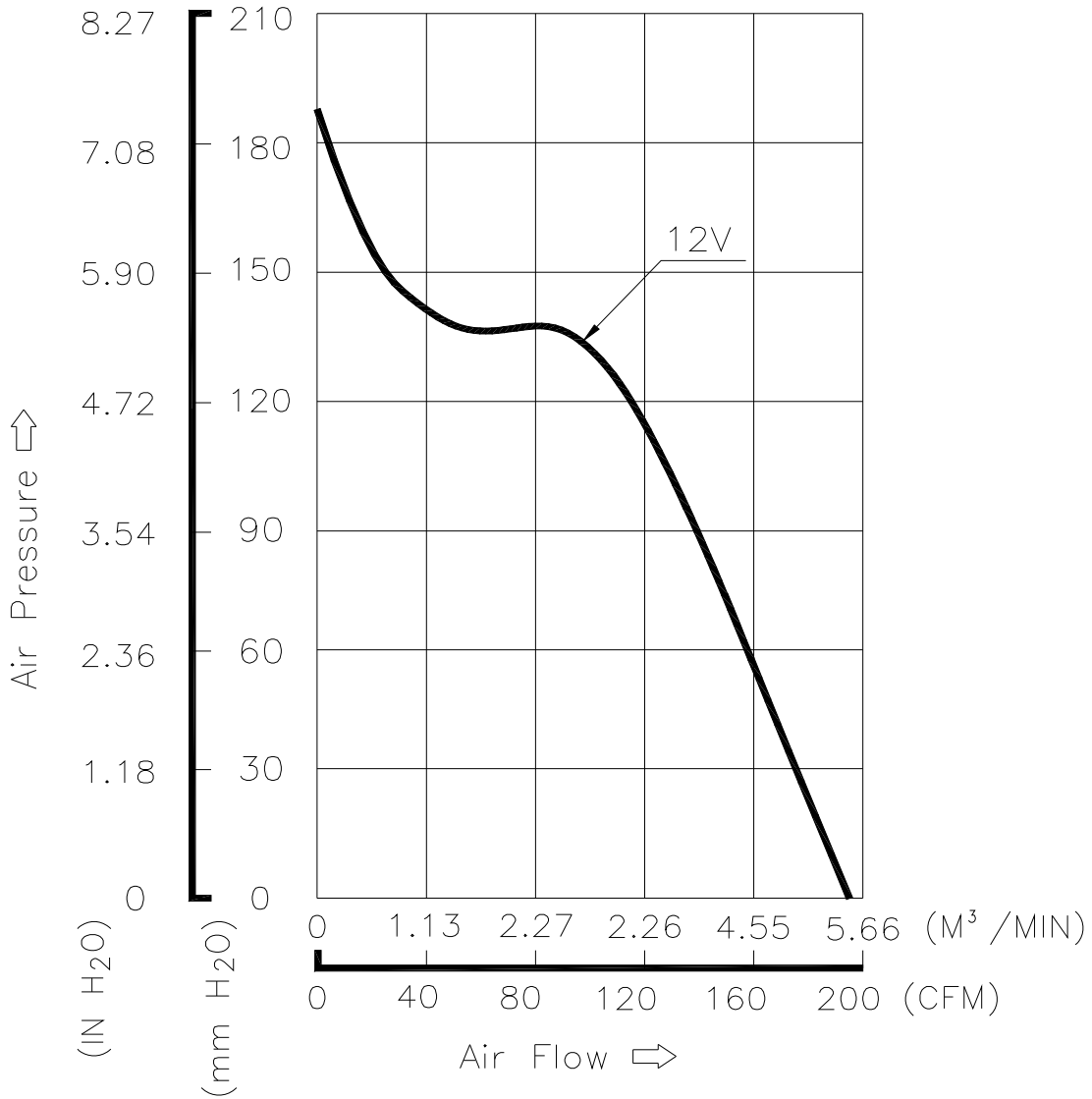

\* TEST CONDITION: INPUT VOLTAGE ----- OPERATION VOLTAGE  
TEMPERATURE ----- ROOM TEMPERATURE  
HUMIDITY ----- 65%RH

PART NO:

DELTA MODEL: THD0812VE-00

9. DIMENSION DRAWING:

LABEL:

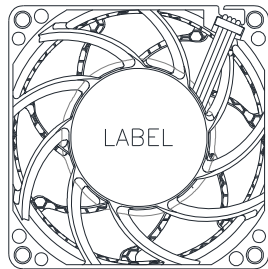
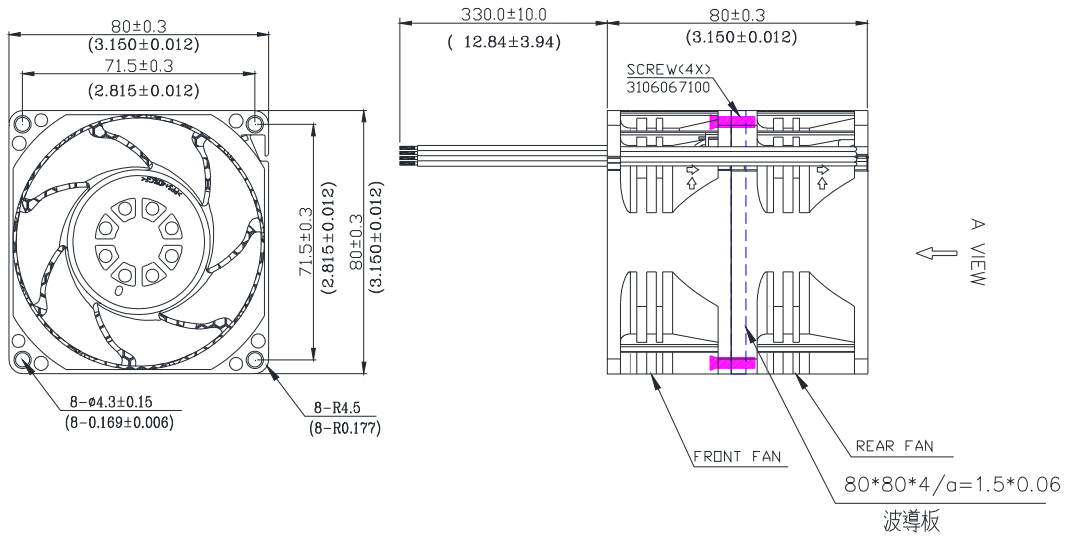
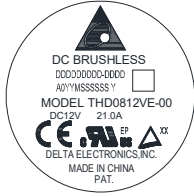

A VIEW

UNIT: MM(INCH)

NOTES :

A. CABLE WIRE:

FRONT FAN

RED WIRE POSITIVE------(+)(UL3265 AWG#18)

BLACK WIRE NEGATIVE-----(-)(UL3265 AWG#18)

BLUE WIRE FREQUENCY-----(-F00)(UL3265 AWG#28)

YELLOW WIRE SPEED CONTROL---(-PWM)(UL3265 AWG#28)

REAR FAN

ORANGE WIRE POSITIVE------(+)(UL3265 AWG#18)

GRAY WIRE NEGATIVE-----(-)(UL3265 AWG#18)

WHITE WIRE FREQUENCY-----(-F00)(UL3265 AWG#28)

PURPLE WIRE SPEED CONTROL---(-PWM)(UL3265 AWG#28)

THIS PRODUCT IS RoHS COMPLIANT



---

PART NO:

---

DELTA MODEL: THD0812VE-00

---

10. MOUNTING PANEL CUTOUT:

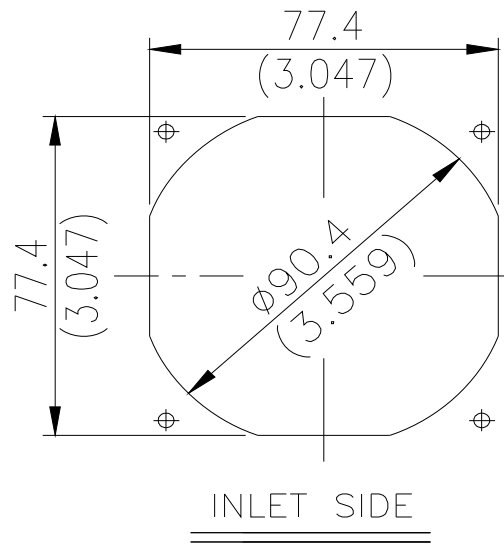
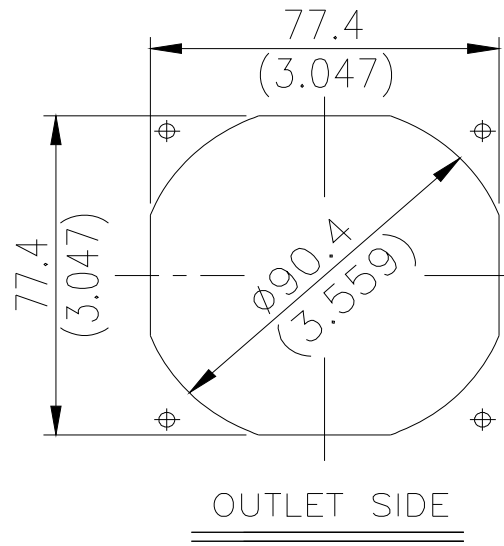

PART NO:

DELTA MODEL: THD0812VE-00

11. FREQUENCY GENERATOR (FG) SIGNAL:

11-1. OUTPUT CIRCUIT - OPEN COLLECTOR MODE:

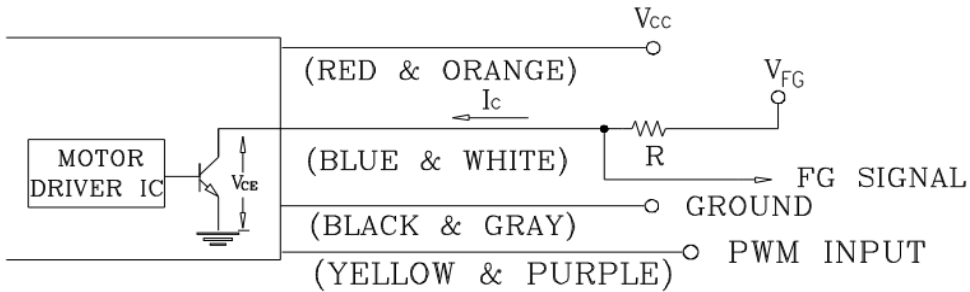

CAUTION: THE FG SIGNAL LEAD WIRE MUST BE KEPT AWAY FROM "+" LEAD WIRE & "-" LEAD WIRE.

11-2. SPECIFICATION:

$$V_{FG} = 13.2V \text{ MAX.}$$

$$I_c = 5mA \text{ MAX.}$$

$$V_{CE} = 0.5V \text{ MAX.}$$

$$R \geq V_{FG} / I_c$$

11-3. FREQUENCY GENERATOR WAVEFORM:



FAN RUNNING FOR 4 POLES

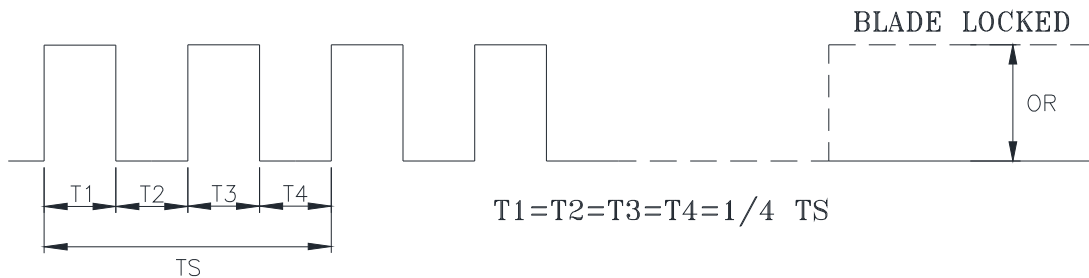

N=RPM

TS=60/N(SEC)

\*VOLTAGE LEVEL AFTER BLADE LOCKED

\*4 POLES

---

PART NO:

---

DELTA MODEL: THD0812VE-00

---

12. PWM CONTROL SIGNAL:

SIGNAL VOLTAGE RANGE: -0.8 ~ 20.0 VDC

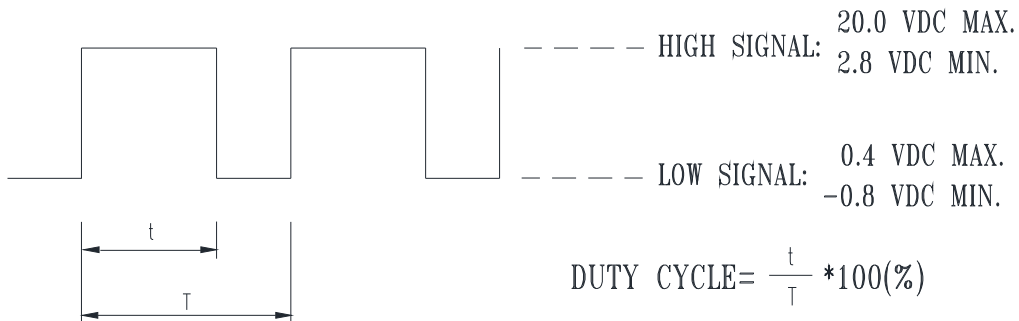

- \*THE FREQUENCY FOR CONTROL SIGNAL OF THE FAN SHALL BE ABLE TO ACCEPT A 600Hz~60KHz.
- \*THE PREFERRED OPERATING POINT FOR THE FAN IS 1KHz.
- \*AT 100% DUTY CYCLE, THE ROTOR WILL SPIN AT MAXIMUM SPEED.
- \*AT 0% DUTY CYCLE, THE ROTOR WILL STOP.
- \*WITH CONTROL SIGNAL LEAD DISCONNECTED, THE FAN WILL SPIN AT MAXIMUM SPEED.
- \*AT 12VDC 1KHz 20% DUTY CYCLE , THE FAN WILL BE ABLE TO START FROM A DEAD STOP .

13. SPEED VS PWM CONTROL SIGNAL:

(AT 12VDC & PWM F=1KHz & TEMP= 25 DEG. C)

| DUTY CYCLE (%) | FOO SPEED RPM (REF.) |           | ACTUAL SPEED RPM (REF.) |           | CURRENT (A) TYP. |
|----------------|----------------------|-----------|-------------------------|-----------|------------------|
|                | FRONT                | REAR      | FRONT                   | REAR      |                  |
| 100            | 15000±10%            | 15000±10% | 15500±10%               | 15500±10% | 15.0A            |
| 50             | 7500±10%             | 7500±10%  | 7750±10%                | 7750±10%  | 2.55A            |
| 10             | 1500±300             | 1500±300  | 1550±300                | 1550±300  | 0.20A            |
| 0              | 0                    | 0         | 0                       | 0         | 0.05A            |

14. PWM CONTROL LEAD WIRE INPUT IMPEDANCE:

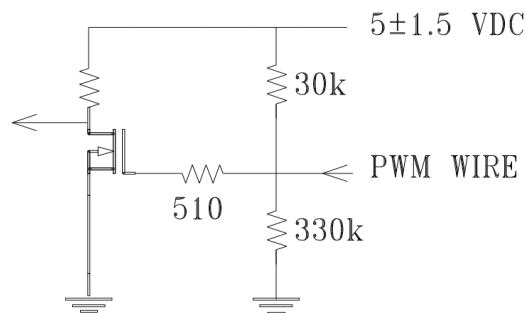

PART NO: 32030298

DELTA MODEL: THD0812VE-00CWH

### 5. FRAME TYPE OF SCREW TORQUE

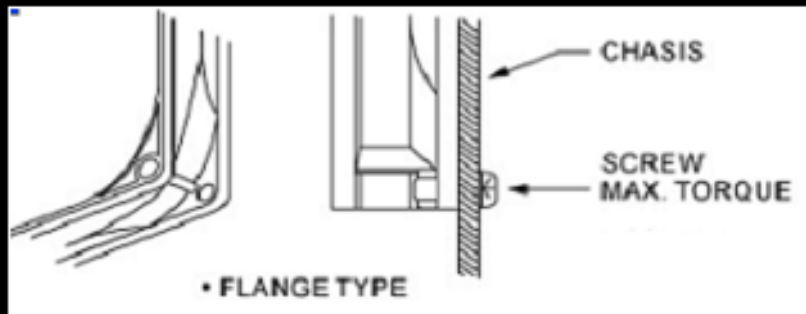

#### MOUNTING DRAWING

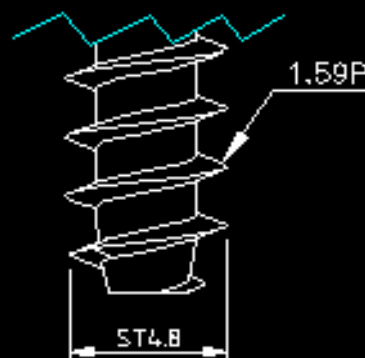

#### SELF-TAPPING SCREW

| MOUNTING HOLE<br>DIAMETER | SCREW TYPE   | SCREW SPEC. | RECOMMENDED MAX. TORQUE(kgf-cm) |
|---------------------------|--------------|-------------|---------------------------------|
|                           |              |             | FLANGE TYPE                     |
| φ4.3                      | SELF-TAPPING | ST4.0x1.50  | 5.5                             |

NOTE:

1. FLANGE TYPE.
2. SELF-TAPPING SCREW ACCORDING TO JIS B 1122 TYPE 2.



## ***Application Notice***

- 1. Delta will not guarantee the performance of the products if the application condition falls outside the parameters set forth in the specification.**
- 2. A written request should be submitted to Delta prior to approval if deviation from this specification is required.**
- 3. Please exercise caution when handling fans. Damage may be caused when pressure is applied to the impeller, if the fans are handled by the lead wires, or if the fan was hard-dropped to the production floor.**
- 4. Except as pertains to some special designs, there is no guarantee that the products will be free from any such safety problems or failures as caused by the introduction of powder, droplets of water or encroachment of insect into the hub.**
- 5. The above-mentioned conditions are representative of some unique examples and viewed as the first point of reference prior to all other information.**
- 6. It is very important to establish the correct polarity before connecting the fan to the power source. Positive (+) and Negative (-). Damage may be caused to the fans if connection is with reverse polarity, if there is no foolproof method to protect against such error specifically mentioned in this spec.**
- 7. Delta fans without special protection are not suitable where any corrosive fluids are introduced to their environment.**
- 8. Please ensure all fans are stored according to the storage temperature limits specified. Do not store fans in a high humidity environment. We highly recommend performance testing is conducted before shipping, if the fans have been stored over 6 months.**
- 9. Not all fans are provided with the Lock Rotor Protection feature. If you impair the rotation of the impeller for the fans that do not have this function, the performance of those fans will lead to failure.**
- 10. Please be cautious when mounting the fan. Incorrect mounting of fans may cause excess resonance, vibration and subsequent noise.**
- 11. It is important to consider safety when testing the fans. A suitable fan guard should be fitted to the fan to guard against any potential for personal injury.**
- 12. Except where specifically stated, all tests are carried out at room (ambient) temperature and relative humidity conditions of 25°C, 65% RH. The test value is only for fan performance itself.**
- 13. Be certain to connect an “ 4.7μF or greater” capacitor to the fan externally when the application calls for using multiple fans in parallel, to avoid any unstable power.**