

PSI-MOS-PROFIB/FO...

FO converter for PROFIBUS up to 12 Mbps



Data sheet
101972_en_13

© PHOENIX CONTACT 2018-09-05

1 Description

The FO converters **PSI-MOS-PROFIB/FO...** convert copper-bound PROFIBUS-DP-interfaces to fiber optics. You can also use the devices in MPI networks (not in ring structures).

As a result of the simple and interference-free networking via fiber optics, bus cable short circuits only affect the actual potential segment concerned. This increases overall availability and improves flexibility in terms of the bus topology. This prevents the negative effects of equipotential bonding currents and EMC interference on the bus lines.

The termination devices **PSI-MOS-PROFIB/FO ... E** convert a PROFIBUS interface to a FO cable. They are ideal for point-to-point connections.

T-couplers **PSI-MOS-PROFIB/FO ... T** convert to two fiber optic cables. They can be used to create redundant bus topologies for increased system availability.

In addition, modular connection stations can be created from both device versions. Devices with different transmission technologies (polymer, PCF, and fiberglass) can be freely combined within a connection station.

Features

- Automatic data rate detection or fixed data rate setting via DIP switches
- Data rate up to 12 Mbps, protocol transparent
- Integrated optical diagnostics for continuous monitoring of fiber optic paths
- Floating switch contact for leading alarm generation in relation to critical fiber optic paths
- Cascadable star and tree structures can be created using bit retiming.
- Electrical isolation between all interfaces
- Supply voltage and data signals routed through a DIN rail connector
- Redundant power supply possible
- Can be combined with the PSI copper repeater for PROFIBUS in a modular way using DIN rail connectors
- PSI-MOS-PROFIB/FO ... -SO versions with coated PCB for increased resistance to salt-laden atmospheres



WARNING: Explosion hazard when used in potentially explosive areas

This device is a category 3 item of electrical equipment. Follow the instructions provided here during installation and observe the safety notes.



Make sure you always use the latest documentation. It can be downloaded at [phoenixcontact.net/products](https://www.phoenixcontact.net/products).



This data sheet is valid for all products listed on the following page:

2 Table of contents

1	Description.....	1
2	Table of contents	2
3	Ordering data.....	3
4	Technical data	4
5	Safety regulations and installation notes.....	7
	5.1 Installation notes	7
	5.2 Installation in zone 2.....	7
	5.3 UL notes.....	7
6	Network structures.....	8
7	Construction	10
	7.1 Dimensions	10
	7.2 Block diagram	10
	7.3 Function elements.....	11
	7.4 Idle setting.....	13
	7.5 Interfaces	13
8	Configuration	14
	8.1 Setting the DIP switches.....	14
	8.2 Setting the data rate (DIP switch 1-4)	15
	8.3 Echo evaluation (DIP switch 5).....	15
	8.4 Connection to fiber optic interfaces from third-party suppliers (DIP switch 5/6)	15
	8.5 Redundancy function (DIP switch 7/9)	16
	8.6 Activating enhanced ring management (DIP switch 7/9)	16
	8.7 Switching off the second fiber optics port (DIP switch 8)	17
	8.8 Activate the FIBER CONTROL function (DIP switch 10)	17
	8.9 Mixed operation of PSI-MOS and PSM-EG.....	17
9	Mounting.....	19
	9.1 Installation in potentially explosive areas.....	20
	9.2 Dismantling	20
10	Supply voltage	21
	10.1 Operation as a single device	21
	10.2 Operation in a connection station	21
11	PROFIBUS interface.....	22
12	Fiber optics interface (FO port)	23
13	Switching output	24
14	Configuration rules.....	25
	14.1 Configuring the network parameters (PSI-MOS devices with 10-pos. DIP switch)	25
	14.2 Configuring the network parameters (PSI-MOS devices with 8-pos. DIP switch)	28

3 Ordering data

Description	Type	Order No.	Pcs./Pkt.
FO converter with integrated optical diagnostics, alarm contact for PROFIBUS up to 12 Mbps, for 660 nm, for polymer/PCF fiber cable, FSMA			
Termination device with one fiber optic interface	PSI-MOS-PROFIB/FO 660 E	2708290	1
T-coupler with two fiber optic interfaces	PSI-MOS-PROFIB/FO 660 T	2708287	1
FO converter with integrated optical diagnostics, alarm contact for PROFIBUS up to 12 Mbps, for 850 nm, fiberglass cable, B-FOC (ST®)			
Termination device with one fiber optic interface	PSI-MOS-PROFIB/FO 850 E	2708274	1
T-coupler with two fiber optic interfaces	PSI-MOS-PROFIB/FO 850 T	2708261	1
FO converter, as described above but with coated PCB for increased resistance to salt-laden atmospheres			
Termination device with one fiber optic interface	PSI-MOS-PROFIB/FO 850 E-SO	2708711	1
T-coupler with two fiber optic interfaces	PSI-MOS-PROFIB/FO 850 T-SO	2708614	1

Other FO converters

Description	Type	Order No.	Pcs./Pkt.
FO converter with integrated optical diagnostics, alarm contact, for PROFIBUS up to 12 Mbps, 1300 nm, for fiberglass cable, SC duplex			
Multi-mode fiberglass cable, up to 25 km			
Single-mode fiberglass cable, up to 45 km			
Termination device with one fiber optic interface	PSI-MOS-PROFIB/FO1300 E	2708559	1
T-coupler with two fiber optic interfaces	PSI-MOS-PROFIB/FO1300 T	2708892	1

Accessories

Description	Type	Order No.	Pcs./Pkt.
DIN rail power supply unit, primary-switched, slim design, output: 24 V DC/1.5 A	MINI-SYS-PS 100-240AC/24DC/1.5	2866983	1
DIN rail power supply unit, primary-switched, slim design, output: 24 V DC/1.5 A, ATEX approval	MINI-PS-100-240AC/24DC/1.5/EX	2866653	1
End bracket	CLIPFIX 35	3022218	50
DIN rail connector, power supply and data (2 per device)	ME 17.5 TBUS1.5/5-ST-3.81GN	2709561	10
DIN rail connector, power supply only (2 per device)	ME 17.5 TBUS1.5/PP000-3.81BK	2890014	10
Small, angled PROFIBUS plug with screw connection	SUBCON-PLUS-PROFIB/SC2	2708232	1
Small, angled PROFIBUS plug with screw connection and additional PG connection	SUBCON-PLUS-PROFIB/PG/SC2	2708245	1
Polymer fiber connectors (4 connectors in a set)	PSM-SET-FSMA/4-KT	2799720	1
Polishing set for polymer fiber connectors (required to assemble polymer fiber connectors)	PSM-SET-FSMA-POLISH	2799348	1
Polymer fiber cable (fiber optic) for indoor installation	PSM-LWL-KDHEAVY	2744319	1
FSMA PCF fiber connectors (4 connectors in the set)	PSM-SET-FSMA/4-HCS	2799487	1
B-FOC (ST®) PCF fiber connectors (4 connectors in the set)	PSM-SET-B-FOC/4-HCS	2708481	1

Accessories

Description	Type	Order No.	Pcs./Pkt.
Tool set for PCF connectors (FSMA) (required for PCF connector assembly)	PSM-HCS-KONFTOOL	2799526	1
Tool set for PCF connectors B-FOC (ST [®]) (required for PCF connector assembly)	PSM-HCS-KONFTOOL/B-FOC	2708465	1
Tool set for FSMA and SC-RJ connectors (polymer fiber)	PSM-POF-KONFTOOL	2744131	1
PCF cable (fiber optic) for indoor installation	PSM-LWL-HCS RUGGED-200/230	2799885	1
PCF cable (fiber optic) for outdoor installation	PSM-LWL-HCSO-200/230	2799445	1
Fiber optic fiberglass cable for indoor installation	PSM-LWL-GDM-RUGGED-50/125	2799322	1
Fiber optic fiberglass cable for outdoor installation	PSM-LWL-GDO-50/125	2799432	1
Measuring instrument for fiber optic power measurement	PSM-FO-POWERMETER	2799539	1

4 Technical data

Power supply	PSI-MOS-PROFIB/FO 660...	PSI-MOS-PROFIB/FO 850...
Power supply	18 V DC ... 30 V DC (via pluggable COMBICON screw terminal block)	
Maximum current consumption	130 mA	
Typical current consumption	100 mA (24 V DC)	120 mA (24 V DC)
Electrical isolation	(VCC // RS-485)	
Test voltage data interface/power supply	1.5 kV _{rms} (50 Hz, 1 min.)	
Tightening torque	0.56 Nm ... 0.79 Nm	

PROFIBUS according to IEC 61158, RS-485, 2-wire, half duplex, automatic control

Operation mode	Half duplex	
Connection method	D-SUB 9 socket	
Data format/coding	UART (11 bits, NRZ)	
Data direction changeover	Automatic	
Serial transmission speed	≤ 12 Mbps	
Transmission length	≤ 1200 m (with shielded, twisted-pair data line depending on the data rate)	
Transmission medium	2-wire twisted pair, shielded	
Output voltage	5 V DC (±0.25), 50 mA	

FO interface	PSI-MOS-PROFIB/FO 660...	PSI-MOS-PROFIB/FO 850...
Connection method	FSMA	B-FOC (ST [®])
Wavelength	660 nm	850 nm
Transmission length including 3 dB system reserve	70 m (with F-P 980/1000 230 dB/km with a quick mounting connector) 400 m (with F-K.200/230 10 dB/km with a quick mounting connector)	800 m (with F-K 200/230 10 dB/km with a quick mounting connector) 2600 m (with F-G 50/125 2.5 dB/km) 3300 m (with F-G 62.5/125 3.0 dB/km)
Minimum transmission length	1 m with F-K 200/230; 8 dB/km	

FO interface	PSI-MOS-PROFIB/FO 660...	PSI-MOS-PROFIB/FO 850...
Minimum transmission power	-3 dBm (980/1000 μ m) -15.4 dBm (200/230 μ m)	-4.2 dBm (200/230 μ m) -17.8 dBm (50/125 μ m) -14.6 dBm (62.5/125 μ m)
Minimum receiver responsiveness	-30 dBm	-30 dBm (50/125 μ m)
Overrange receiver	-3 dBm (980/1000 μ m)	-3 dBm (200/230 μ m)
Transmission protocol	Transparent protocol to RS-485 interface	

General data

Degree of protection	IP20
Dimensions (W/H/D)	35 mm x 99 mm x 106 mm
Weight	190 g (Termination device) 250 g (T-coupler)
Enclosure material	PA 6.6-FR, green
Free fall according to IEC 60068-2-32	1 m
Vibration resistance according to EN 60068-2-6/ IEC 60068-2-6	5g, 150 Hz, 2.5 h, in XYZ direction
Shock according to EN 60068-2-27/IEC 60068-2-27	15g, 11 ms period, half-sine shock pulse
Air clearances and creepage distances	DIN EN 60664-1/VDE 0110-1, DIN EN 50178, DIN EN 60950
Bit distortion, input	\pm 35 % (permissible)
Bit distortion, output	< 6.25 %
Bit delay in standard operation (DIP 7 = OFF)	< 1 bit (configurable)
Bit delay in redundancy mode (DIP 7 = ON)	11 bit
Switching output, switching voltage, maximum	60 V DC 42 V AC
Switching output, limiting continuous current	0.46 A

MTTF times	PSI-MOS- PROFIB/ FO 660 E	PSI-MOS- PROFIB/ FO 660 T	PSI-MOS- PROFIB/ FO 850 E	PSI-MOS- PROFIB/ FO 850 T
MTTF (Mean Time To Failure) SN 29500 standard, temperature 25 °C, operating cycle 21% (5 days per week, 8 hours per day)	243 years	213 years	247 years	212 years
MTTF (Mean Time To Failure) SN 29500 standard, temperature 40 °C, operating cycle 34.25% (5 days per week, 12 hours per day)	178 years	150 years	200 years	150 years
MTTF (Mean Time To Failure) SN 29500 standard, temperature 40 °C, operating cycle 100% (7 days per week, 24 hours per day)	110 years	86 years	130 years	86 years

Ambient conditions

Ambient temperature (operating)	-20 °C ... 60 °C
Ambient temperature (storage/transport)	-40°C ... 85°C
Permissible humidity (operation)	30% ... 95% (non-condensing)

Approvals

Conformance	CE-compliant, EAC
Free from substances that would hinder coating with paint or varnish	According to VW-AUDI-Seat central standard P-VW 3.10.7 57 65 0
ATEX (Please follow the special installation instructions in the documentation)	Ⓢ II 3 G Ex nA nC IIC T4 Gc X Ⓢ II (2) G [Ex op is Gb] IIC (PTB 06 ATEX 2042 U) Ⓢ II (2) D [Ex op is Db] IIIC (PTB 06 ATEX 2042 U)
UL, USA/Canada	Class I, Zone 2, AEx nc IIC T5 Class I, zone 2, Ex nC nL IIC T5 X Class I, Div. 2, Groups A, B, C, D
PROFIBUS interoperability	Tested by independent PNO test laboratory (PN059-485-01)
ABB certification: Industrial IT enabled This certification is a trademark of ABB.	
Shipbuilding approval	DNV

Conformity with EMC Directive 2014/30/EU**Noise immunity according to EN 61000-6-2**

Electrostatic discharge	EN 61000-4-2	
	Contact discharge	± 6 kV
	Air discharge	± 8 kV
	Comment	Criterion B
Electromagnetic HF field	EN 61000-4-3	
	Field strength	10 V/m
	Comment	Criterion A
Fast transients (burst)	EN 61000-4-4	
	Input	± 2 kV
	Signal	± 2 kV
	Comment	Criterion B
Surge current loads (surge)	EN 61000-4-5	
	Input	± 0.5 kV
	Signal	± 1 kV
	Comment	Criterion B
Conducted interference	EN 61000-4-6	
	Voltage	10 V
	Comment	Criterion A

Noise emission according to EN 61000-6-4

Noise emission	EN 55011 class A industrial area of application
Criterion A	Normal operating behavior within the specified limits
Criterion B	Temporary adverse effects on the operating behavior, which the device corrects automatically

5 Safety regulations and installation notes

5.1 Installation notes



WARNING:

Observe the following safety notes when using the FO converter.

- The category 3 device is suitable for installation in Zone 2 potentially explosive areas. It meets the requirements of EN 60079-0:2012+A11:2013 and EN 60079-15:2010.
- The FO components of type PSI-MOS transmitter control 660 or 850 are a part of the module. The fibre optics interface is used for optical communication with devices used in the potentially explosive area of zone 1 or zone 21. It is used in accordance with the EC examination certificate.
- Installation, operation, and maintenance may only be carried out by qualified electricians. Follow the installation instructions as described. When installing and operating the device, the applicable regulations and safety directives (including national safety directives), as well as the general codes of practice, must be observed. The safety data is provided in the packing slip and on the certificates (conformity assessment, additional approvals where applicable).
- The device must not be opened or modified apart from the configuration of the DIP switches.
- Do not repair the device yourself; replace it with an equivalent device instead. Repairs may only be carried out by the manufacturer. The manufacturer is not liable for damage resulting from non-compliance.
- The IP20 degree of protection (IEC 60529/EN 60529) of the device is intended for use in a clean and dry environment. Do not subject the device to mechanical and/or thermal loads that exceed the specified limits.

- The switches of the device that can be accessed may only be actuated when power to the device is disconnected.
- The device is designed exclusively for operation with safety extra-low voltage (SELV) according to IEC 60950/EN 60950/VDE 0805. The device may only be connected to devices that meet the requirements of EN 60950.

5.2 Installation in zone 2



WARNING: Explosion hazard when used in potentially explosive areas

Make sure that the following notes and instructions are observed.

- Observe the specified conditions for use in potentially explosive areas!
- Install the device in a suitable, approved housing (with at least IP54 protection) that meets the requirements of EN 60079-15. For this purpose, observe the requirements of IEC 60079-14 / EN 60079-14.
- Only connect devices to the supply and signal circuits in zone 2 that are suitable for operation in Ex zone 2 and for the conditions at the installation location.
- In potentially explosive areas, only snap the device onto or off the DIN rail connector and connect/disconnect cables when the power is disconnected.
- The device must be stopped and immediately removed from the Ex area if it is damaged, was subjected to an impermissible load, stored incorrectly or if it malfunctions.
- Connection to the D-SUB interface is only permitted if the screw connection is tightened.

5.3 UL notes

PROCESS CONTROL EQUIPMENT FOR HAZARDOUS LOCATIONS 31ZN

- This equipment is suitable for use in Class I, Zone 2, AEx nC IIC T5, Ex nC nL IIC T5 X; and Class I, Division 2, Groups A, B, C and D or non-hazardous locations only.
- WARNING - EXPLOSION HAZARD** - substitution of components may impair suitability for Class I, Zone 2/Division 2.
- WARNING - EXPLOSION HAZARD** - do not disconnect equipment unless power has been switched off or the area is known to be non-hazardous.
- This device must be installed in an enclosure rated IP54 and used in an area of not more than pollution degree 2.

6 Network structures

The PSI-MOS-PROFIB/FO... system can be used to create network structures that are tailored to the relevant application. To create the illustrated network structures you will need:

- T-coupler (PSI-MOS-PROFIB/FO ... T)
- Termination devices (PSI-MOS-PROFIB/FO ... E)

Point-to-point connections

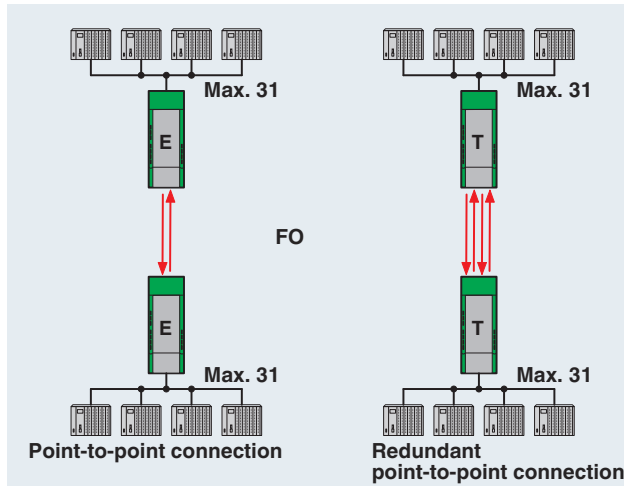

You can use two termination devices to easily convert a data link from copper cable to fiber optics.

For increased availability, the point-to-point connection can also be designed redundantly. To do so, you will need two T-couplers.

Linear structures

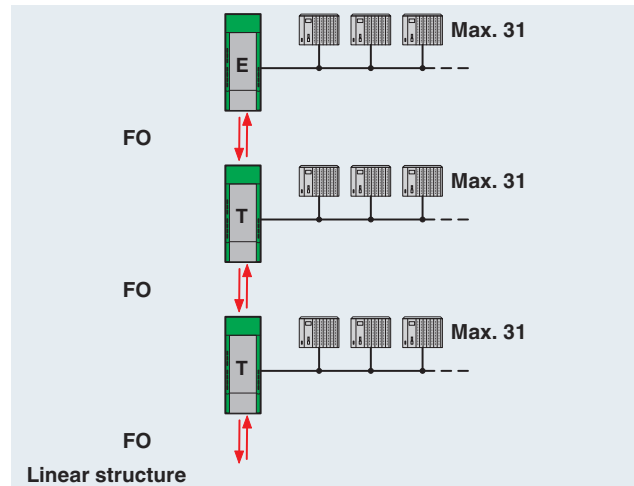

You can network several devices to form a line structure.

- Termination devices are used at the beginning and end of the fiber optic path.
- T-couplers with two fiber optic ports are used along the line.

Star structures

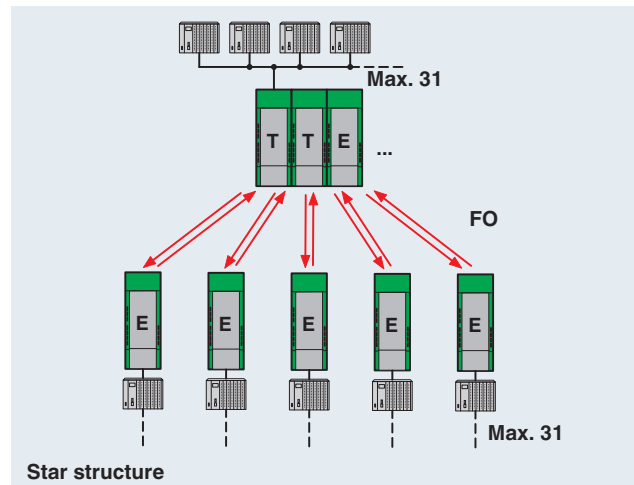

You can also network PROFIBUS devices in a star structure. To do so, connect several T-couplers and termination devices to an active star coupler.

You can interconnect up to ten devices for each star coupler. Cross-wiring for the RS-485 data and the power supply is provided by the DIN rail connector.

Tree structures

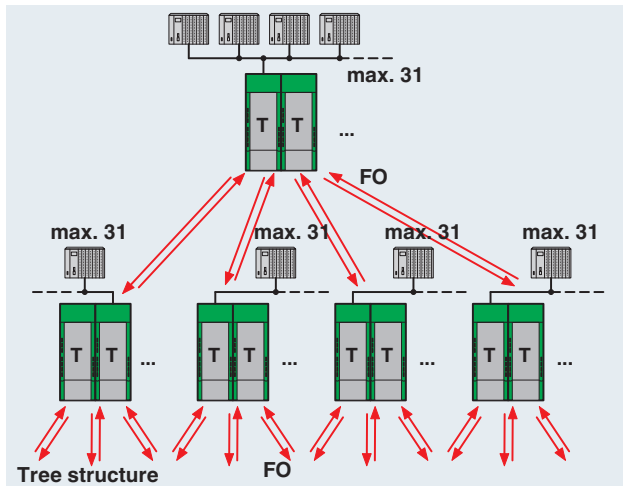

You can cascade line and star structures to create complex tree structures, including in a redundant version if required. The maximum number of devices that can be cascaded is only limited by the timing response of the bus system used due to the bit retiming of the FO converter.

Redundant ring structures

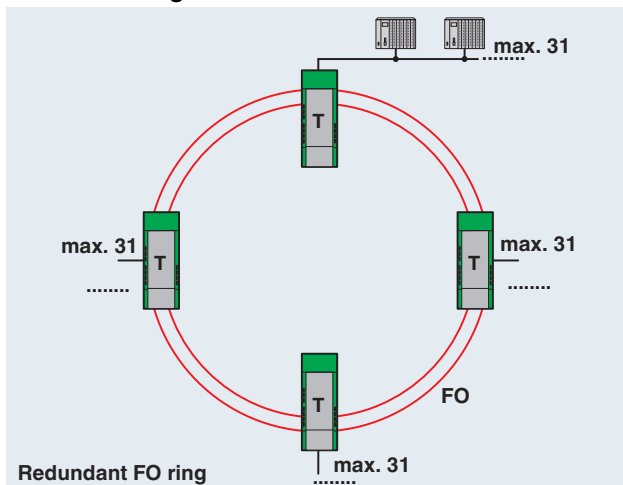

If a system has increased requirements in terms of transmission reliability and availability, redundant ring structures can be created. If a fiber optic subsection in this topology breaks down (broken fiber), all the other devices can still be accessed. In MPI networks, redundant ring structures cannot be created.

In the redundant ring, mixed operation of PSI-MOS with FO interfaces from other manufacturers is not permitted.

7 Construction

7.1 Dimensions

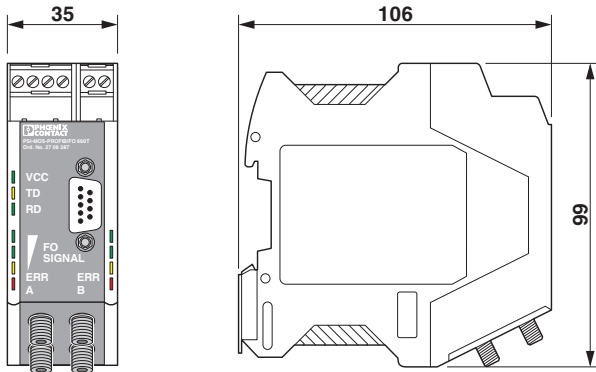

Figure 1 Housing dimensions

7.2 Block diagram

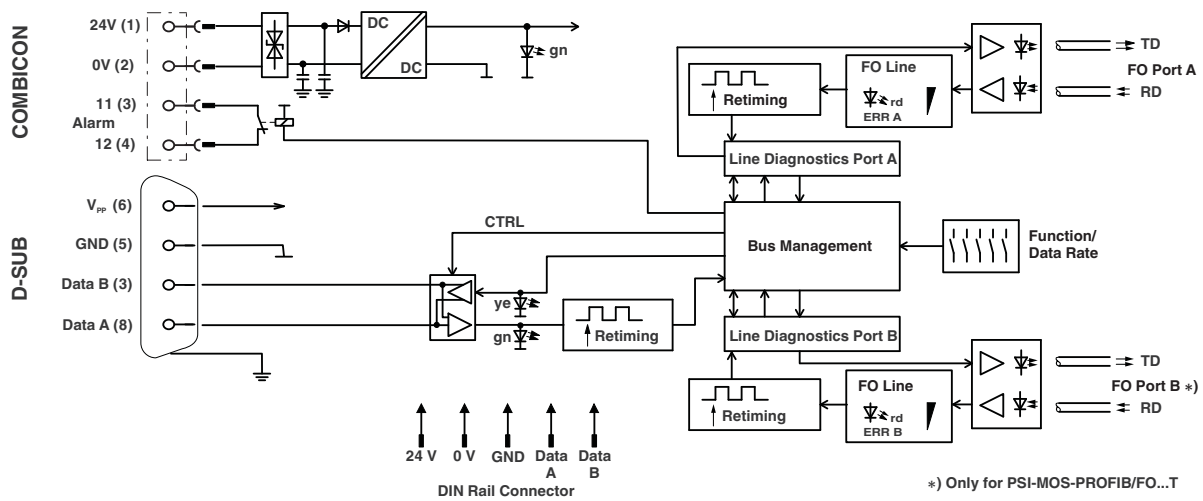

Figure 2 Block diagram (port B only with T-couplers PSI-MOS-PROFIB/FO ... T)

7.3 Function elements

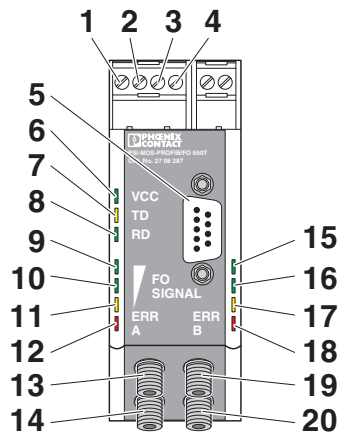

Figure 3 Function elements

- 1 24 V DC supply voltage
- 2 0 V DC supply voltage
- 3 N/C contact, connection 11
- 4 N/C contact, connection 12
- 5 D-SUB 9 PROFIBUS interface
- 6 LED VCC Supply voltage
- 7 LED TD Dynamic transmission data to D-SUB
- 8 LED RD Dynamic receive data to D-SUB
- 9 LED Port A FO signal
- 10 LED Port A FO signal
- 11 LED Port A FO signal
- 12 LED Port A ERR
- 13 Fiber optic transmitter, port A
- 14 Fiber optic receiver, port A

Port B only with T-couplers

PSI-MOS-PROFIB/FO ... T:

- 15 LED Port B FO signal
- 16 LED Port B FO signal
- 17 LED Port B FO signal
- 18 LED Port B ERR
- 19 Fiber optic transmitter, port B
- 20 Fiber optic receiver, port B

Diagnostic and status indicators

LED	Color	Meaning
VCC	Green	On: Transmission speed detected or set Flashing (1 Hz): No valid transmission speed detected (autobaud setting)
TD	Yellow	Data is sent to the PROFIBUS interface (D-SUB 9).
RD	Green	Data is received at the PROFIBUS interface (D-SUB 9).

LED indicators of the FO interface

The quality of the path is determined using the incoming optical power P_{opt} and displayed using the LED bar graphs. In the default setting, the DIP switch 6 is set to OFF (INVERSE). In the idle state (rest period between transmitting data), the transmitters switch to permanent light to enable continuous fiber optic diagnostics.

If you switch DIP 6 to ON (NORM), the echo evaluation (DIP 5 = OFF) is available as diagnostics. If you switch the echo evaluation off (DIP 5 = ON), fiber optic diagnostics are not available.

DIP	ON	OFF (default setting)
5	MIXED	-
6	STANDARD Logic 1 = Light off	INVERSE Logic 1 = Light on

LED		Receive signal	Optical power P_{opt}
FO signal	Green	Receiving power is very good	Significantly greater than system reserve
	Green	Receiving power is good	Still greater than system reserve
	Yellow	Receiving power is critical	P_{opt} has reached the system reserve.
ERR	Red	Receiving power is insufficient, broken fiber	P_{opt} has sapped the system reserve/ broken fiber

As soon as the system reserve is reached, only the yellow LED remains lit. At the same time, the signaling relay drops and the switching output opens. Data communication is still possible.

In "Redundant ring" operating mode, the affected FO port is already switched off when the LED goes to yellow to prevent any risk of data corruption.

7.4 Idle setting

During the idle phase, fiber optic interfaces return to an idle setting defined by the manufacturer.

This idle setting may vary for different manufacturers and devices. As fiber optic interfaces can only be operated together if they have the same idle setting, this should be observed in mixed operation with third-party devices (see "Connection to fiber optic interfaces from third-party suppliers (DIP switch 5/6)" on page 15).

For PSI-MOS, the idle setting is specified as "Light on" (corresponds to "Logic 1").



When connecting third-party devices, observe the receiver sensitivity and overrange limits of the fiber optic interfaces.

7.5 Interfaces

The devices have three or four interfaces for the PROFIBUS signal:

- Electrical interface (D-SUB)
- DIN rail connector
- FO port A
- Fiber optics port B (only with T-couplers
PSI-MOS-PROFIB/FO ... T)

All interfaces communicate with one another with the same rights. If a signal is present at one of the interfaces, this signal is also available to all other interfaces.

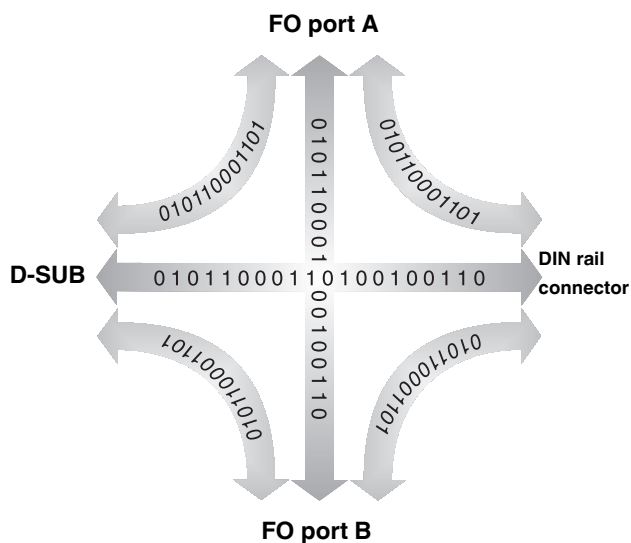

Figure 4 Communication between the interfaces

8 Configuration

Changes to the default settings are only required in the following cases:

- Operation with fixed transmission rate (default setting: automatic data rate detection)
- Operation in a redundant ring
- Operation of a PSI-MOS-PROFIB/FO ... T T-coupler with only one fiber optic port (switch off fiber optic port B)
- Direct connection to fiber optic interfaces from other manufacturers
- Mixed operation of PSI-MOS with the old PSM-EG series. Usually, you must adjust the differing idle settings of the two series.
- Mixed operation of PSI-MOS with 8-pos. and 10-pos. DIP switches. Devices with 10-pos. DIP switches have been supplied since April 2006 and offer enhanced functions.

In all other cases, you can operate the devices using the default settings.

8.1 Setting the DIP switches



NOTE: Electrostatic discharge

The module contains components that can be damaged or destroyed by electrostatic discharge. When handling the device, observe the necessary safety precautions against electrostatic discharge (ESD) according to EN 61340-5-1 and IEC 61340-5-1.



Select the operating mode only when the power is disconnected! The change is activated after renewed power up.

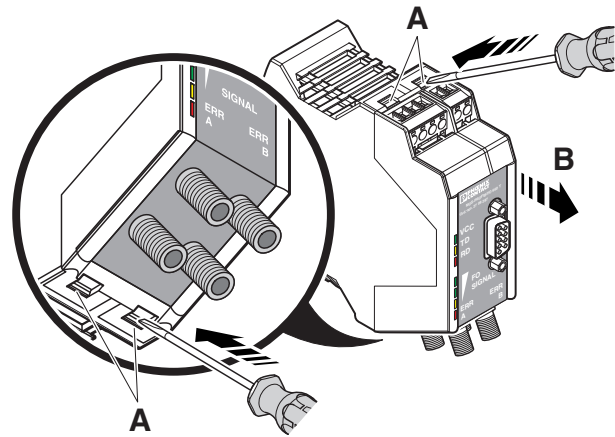

Figure 5 Opening the housing

- Release the housing cover using a screwdriver (A).
- Then carefully pull the printed-circuit board out of the housing as far as possible (B).

By default upon delivery, all DIP switches are in the "OFF" position.

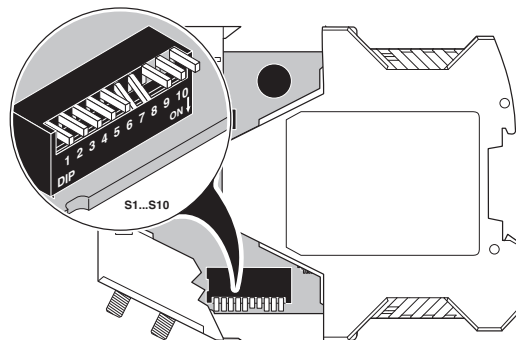

Figure 6 DIP switch

DIP	ON	OFF (default setting)
1	Data rate (see table below)	
2		
3		
4		
5	MIXED	-
6	STANDARD	INVERSE
7 ¹	REDUNDANCY	-
8 ¹	END	NEXT
9	COMPATIBILITY	-
10	FIBER CONTROL	-

¹ No function for PSI-MOS-PROFIB/FO ... E termination devices

8.2 Setting the data rate (DIP switch 1-4)

The devices are equipped with automatic data rate detection. If necessary, you can also specify a fixed transmission rate, which considerably reduces the initialization time of the whole system.

- Set the transmission speed using the DIP switches.

• = ON	DIP 1	DIP 2	DIP 3	DIP 4
Data rate [kbps]				
Autobaud				
12000				•
6000			•	
3000			•	•
1500		•		
500		•		•
187.5		•	•	
93.75		•	•	•
45.45	•			
19.2	•			•
9.6	•		•	

8.3 Echo evaluation (DIP switch 5)

Echo evaluation is useful for the mixed operation of PSI-MOS and PSM-EG devices (older generation of Phoenix Contact fiber optic converters). Although PSM-EG devices offer echo evaluation, they do not offer the permanent diagnostics (FO signal) provided by PSI-MOS devices. Therefore, the echo evaluation of the FO fibers is monitored. For additional information about the configuration of devices in mixed operation, please refer to Section "Mixed operation of PSI-MOS and PSM-EG" on page 17.

Echo evaluation (DIP 5 = "OFF") is used to detect broken fibers for the devices. During the idle phase (rest period between transmitting data), the fiber optics between directly connected devices are monitored for broken fibers.

If there is a broken fiber, the respective FO fiber is switched off, the error LED is set and the switching output is activated.

If the default setting for DIP 6 = "OFF" (INVERSE) is used, echo evaluation is switched off because the built-in diagnostics (FO signal) permanently evaluates the received signal and therefore also detects a broken fiber.

In a redundant ring (DIP 7 = "ON"), echo evaluation is always available, regardless of DIP switches 5 and 6.

You must always switch off the echo evaluation in the following operation cases:

- Operation with data rates more than 1.5 Mbps (e.g. 3 Mbps), since a broken fiber could be detected with long FO fibers due to the correspondingly long cable times.
- Mixed operation of PSI-MOS with FO interfaces from third-party suppliers (see chapter "Mixed operation of PSI-MOS and PSM-EG" on page 17).

8.4 Connection to fiber optic interfaces from third-party suppliers (DIP switch 5/6)

During the idle phase, fiber optic interfaces return to an idle setting defined by the manufacturer. This idle setting may vary for different manufacturers and devices. As fiber optic interfaces can only be operated together if they have the same idle setting, this should be set using the DIP switches.

For mixed operation of PSI-MOS with fiber optic interfaces from other manufacturers, observe the following specifications:

- Deactivate the echo evaluation.
To do this, set DIP 5 to "ON".
- Check the idle setting for the third-party interface:
 - Logic 1 = Light off or
 - Logic 1 = Light on
- If necessary, adjust the idle setting of PSI-MOS with DIP 6.

DIP	ON	OFF (default setting)
5	MIXED	-
6	STANDARD Logic 1 = Light off	INVERSE Logic 1 = Light on

In the "OFF" position, continuous measurement of the received optical power is available. The reception quality is displayed by means of a 4-level bar graph (FO signal). In these operating conditions, the echo evaluation is automatically shut off.

In the "ON" position, continuous measurement of the received optical power is not available. The 4-level bar graph is switched off. If echo evaluation is also switched off (DIP 5 = "ON"), broken fiber detection is not available either. In this combination, the PSI-MOS devices do not have any diagnostics of the fiber optic path.



For mixed operation with devices of other manufacturers, observe the receiver sensitivity and overrange limits of the fiber optic interfaces. In the redundant ring, mixed operation with FO interfaces of other manufacturers is not permitted.



If DIP 6 is set to "ON", the FO diagnostics are not available via the LED bar graphs. The LED bar graph can light up at high transmission speeds or flash at low transmission speeds. This display does **not** correspond to continuous evaluation of the optical power.

8.5 Redundancy function (DIP switch 7/9)



The redundancy function is only intended for use in the "redundant ring" network structure (see Page 9).

- For path structures (point-to-point, linear, star, etc.), switch off the redundancy function (DIP 7 = OFF).

When you activate the redundancy function, the corresponding FO port is switched off automatically as soon as the receive quality reaches "System reserve reached" (only the yellow and red LEDs are lit). This enables you to prevent any data corruption.

When the fiber optic ports are switched off, the red ERR LED lights up on the affected port for both termination devices. In the redundant ring, data communication continues via the second fiber optic port after the first fiber optic port is switched off.

For path structures, activating the redundancy function results in the affected fiber optic port being switched off in the event of a weak fiber optic signal (yellow LED) and thus causes the subsequent part of the network to fail.

In order to eliminate the ring length limits and the maximum transmission rate of 1.5 Mbps, an expanded redundancy management was implemented in PSI-MOS. The expanded redundancy management is only used for T-couplers, since it is not possible to create a redundant ring with termination devices.

The new redundancy management solution is based on the parameterization of a non-existent device in STEP 7[®]. This means that there are no limits in terms of the ring length.

To ensure compatibility with PSI-MOS devices that use the old redundancy management solution, an additional DIP switch (DIP 9 "COMPATIBILITY") has been added. PSI-MOS devices with the new redundancy management solution have a 10-pos. DIP switch range, which makes it easy to distinguish between them and PSI-MOS devices with the old redundancy management solution (8-pos. DIP switch range).

- During mixed operation of both PSI-MOS series in a redundant ring, set DIP switch 7 and DIP switch 9 to ON.

• = ON	DIP 7	DIP 9
8-pos.	•	-
10-pos.	•	•

- Set the other switches according to your application.

8.6 Activating enhanced ring management (DIP switch 7/9)



The expanded ring management can only be used when only PSI-MOS devices with 10-pos. DIP switches are used.

If DIP 9 is left set to "OFF" and DIP 7 is set to "ON", the following functions are available in the redundant ring:

- Increase maximum transmission speed from 1.5 Mbps to 12 Mbps
- No more restrictions regarding the maximum possible ring length
- No more restrictions regarding the maximum possible number of devices

8.7 Switching off the second fiber optics port (DIP switch 8)

If you do not use the fiber optics port B with T-couplers PSI-MOS-PROFIB/FO ... T, you have to switch it off. Otherwise the red LED will light up, "ERR".

- Set DIP 8 to "ON" (END).

8.8 Activate the FIBER CONTROL function (DIP switch 10)



If the devices are operated in the redundant ring (DIP 7 = ON), DIP switch 10 is without function.

If you wish to interrupt transmission of the telegrams between two PSI-MOS devices in **both** directions of the fiber optics path in the event of a failure of **one** optical fiber, activate the FIBER CONTROL function.

- To do this, set DIP 10 to "ON".

If a fiber break is now detected, the PSI-MOS device switches its optical transmitters to permanent light. Now, telegrams will no longer be transmitted on both optical fibers.

Once the received optical power is sufficient, the device automatically resends the received telegram.



Activate this function on all PSI-MOS devices that are connected directly to each other via fiber optic paths.

8.9 Mixed operation of PSI-MOS and PSM-EG

Mixed operation of the old PSM-EG series with the new PSI-MOS is generally possible. Note the following settings and restrictions:

Configuring devices

The setting of the DIP switch depends on the requirements of the application.

- Set the same idle setting for all devices in the system.
- On PSI-MOS device of the latest generation with 10-pos. DIP switches, switch the DIP switch 9 to "ON".

Diagnostics in mixed operation

In mixed operation, the function of the diagnostic evaluation depends on the switch settings of the devices.

Usually, PSM-EG devices and PSI-MOS devices are only combined in the case of exchange or replacement. Therefore the following is based on a given setting of the PSM-EG devices with the PSI-MOS devices being adjusted to this.

If the idle setting is defined as "Light off" for PSM-EG (DIP 6 set to "OFF"), set DIP 6 to "ON" for PSI-MOS. The FO signal is thus no longer available to the PSI-MOS devices and diagnostics is limited to the detection of broken fibers. If the idle setting is defined as "Light on" for PSM-EG (DIP 6 set to "ON"), set DIP 6 to "OFF" for PSI-MOS.

If broken fiber detection is activated for PSM-EG (DIP 7 set to "ON"), set DIP 5 to "OFF" for PSI-MOS. If broken fiber detection is deactivated for PSM-EG (DIP 7 set to "OFF"), set DIP 5 to "ON" for PSI-MOS.

If broken fiber detection is deactivated and the idle setting is defined as "Light off", diagnostics are not available for the fiber optic path.

Overload or underload of the FO interfaces

In rare cases (usually in the case of very short fiber optic connections of just a few meters), an overload of the PSI-MOS devices may occur in mixed operation. This is due to the highly sensitive PSI-MOS receivers, which cover large ranges but can be overloaded on very short fiber optic paths (of just a few meters).

When overloads occur, it is possible to increase the attenuation via a patch cable with FO coupling in order to enable flawless operation.

In mixed operation, observe the following ranges:

Fiber	Wavelength	Maximum range
Glass 50/125	850 nm	1600 m
Glass 62.5/125	850 nm	2200 m
PCF	Not permissible for PSM-EG	
POF	660 nm	70 m

DIP • = ON X = any position						FO diagnostics	Switching off the FO port	Echo evaluation	Restrictions	Operation mode	Third-party connection / Mixed operation
5	6	7	8	9	10						
X			X			Continuous	None	None	None	Line/Star/Tree	Third-party coupler without echo function with "Light on" idle setting
			X	•		Continuous	None	Activated	Path length	Line/Star/Tree	Third-party coupler with echo function and "Light on" idle setting
	•		X	X		None	None	Activated	Restriction of the path length depending on the transmission speed	Line/Star with "Light off" idle setting	–
•	•		X	X		None	None	None	None	Line/Star with "Light off" idle setting	Third-party coupler without echo with "Light off" idle setting
X	X	•				Continuous	Yes, at low receiving power	Cannot be switched off ¹	None	Redundancy standard operating mode. Redundancy mode with fiber optic diagnostics, path monitoring, and enhanced redundancy management	–
X	X	•		•		Continuous	None		Ring length		For mixed operation with different generations of PSI-MOS devices
X			X		•	Continuous	Switching off during a fiber break; telegrams will no longer be transmitted.	None	None	Line/Star/Tree	–

¹ If DIP 7 (REDUNDANCY) is in the "ON" position and DIP 8 (END) is in the "OFF" position, the system switches automatically to the "Light on" idle setting with echo evaluation.
However, if fiber optic port B is switched off by setting DIP 8 to "ON" (END), DIP 7 (REDUNDANCY) has no function.

9 Mounting



CAUTION: Electrical voltage

The device is only intended for operation with SELV according to IEC 60950/EN 60950/VDE 0805.



NOTE: Device damage

Only mount and remove devices when the power supply is disconnected.



NOTE: Malfunction

Connect the DIN rail with the protective earth via a grounding terminal block. The devices are grounded when they are snapped onto the DIN rail (installation according to PELV). This ensures that the shielding is effective. Connect protective earth ground with low impedance.

Mounting as single device

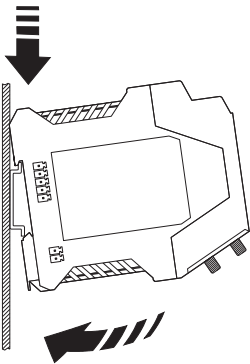

Figure 7 Mounting on a DIN rail

- To avoid contact resistance, use only clean, corrosion-free 35 mm DIN rails in accordance with DIN EN 60715.
- Install an end bracket next to the left-hand device to prevent the devices from slipping.
- Place the device onto the DIN rail from above.
- Push the front of the device toward the mounting surface until it audibly snaps into place.
- Snap the other devices that are to be contacted onto the DIN rail next to one another.

Combined assembly

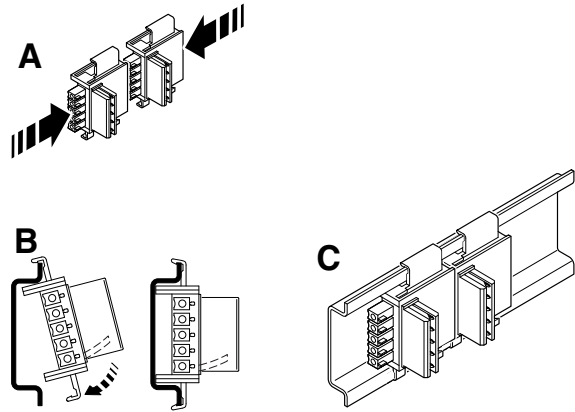

Figure 8 Combined assembly

The DIN rail connector is used to bridge the power supply and communication.

- Connect the DIN rail connectors for a connection station (Order No. 2709561, 2 per device).
- Push the connected DIN rail connectors onto the DIN rail.
- Place the device onto the DIN rail from above.
- Push the front of the device toward the mounting surface until it audibly snaps into place.

A connection station must not consist of more than ten devices.



In this case, note the snap-on direction of the device and DIN rail connector: snap-on foot below and connector part left!

9.1 Installation in potentially explosive areas



WARNING: Explosion hazard when used in potentially explosive areas

Observe the safety notes in Section 5 „Safety regulations and installation notes“.

Areas with a danger of gas explosions

The devices are suitable for use in zone 2. Devices that are installed in zone 1 can be connected to the fiber optics interface. The fiber optic interface is an associated item of equipment with protection type "Ex op is".

Area with a danger of dust explosions

The device is **not** designed for use in atmospheres with a danger of dust explosions.

If dust is present, install the device in suitable, approved housing.

When installed outside of areas with a danger of dust explosions, devices installed in zone 22 or 21 can also be connected to the fiber optic interface.

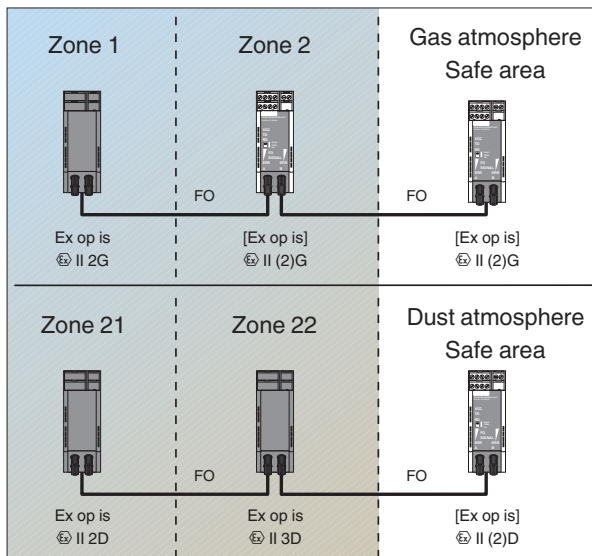

Figure 9 Installation in potentially explosive areas

9.2 Dismantling

- Push down the locking latch using a screwdriver, needle-nose pliers or similar.
- Pull the bottom edge of the device slightly away from the mounting surface.
- Pull the device diagonally upward from the DIN rail.
- When removing a complete connection station, also remove the DIN rail connectors.

10 Supply voltage



CAUTION: Electrical voltage

The device is only intended for operation with SELV according to IEC 60950/EN 60950/VDE 0805.

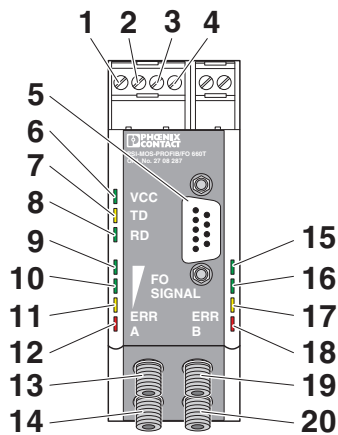

- 1 24 V DC supply voltage
- 2 0 V DC supply voltage

10.1 Operation as a single device

- Supply voltage to the device via the terminals 1 (24 V) and 2 (0 V).

10.2 Operation in a connection station



NOTE: Device damage

- The maximum current load in a connection station must not exceed 2 A.
- A connection station must not consist of more than ten devices.

When the devices are operated in a connection station, the supply voltage must only be supplied to the first device in the station. The remaining devices are supplied via the DIN rail connector.

A second power supply unit can be used to create a redundant supply concept.

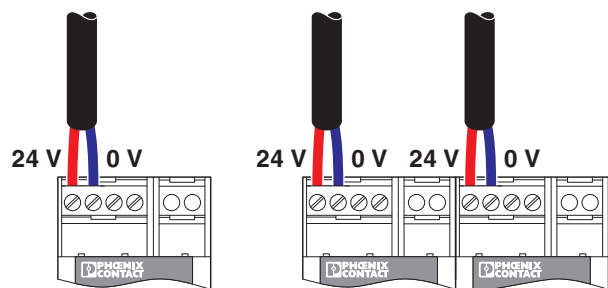

Figure 10 Individual and redundant supply

Using the system power supply unit

Alternatively, the connection station can be connected to a system power supply unit.

- Connect a system power supply to two DIN rail connectors on the left of the group.
(MINI-SYS-PS-100-240AC/24DC/1.5, Order No. 2866983 or MINI-PS100-240AC/24DC/1.5/EX, Order No. 2866653 and two DIN rail connectors, Order No. 2709561)

11 PROFIBUS interface

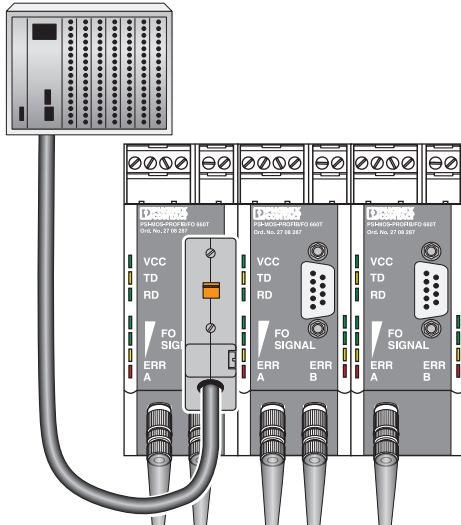

Figure 11 PROFIBUS interface

- Use an approved connector (e.g. SUBCON-PLUS-PROFIB, see Page 3) to connect the bus cable to the D-SUB connection on the PSI-MOS device.
- If the FO converter is used at the beginning or end of an electrical PROFIBUS segment, activate the termination in the connector.



NOTE: Malfunction

The maximum length of the RS-485 cables depends on the transmission speed. Do not exceed the following maximum values.

Transmission speed [kbps]	Range [m]
187.5	1000
500	400
1500	200
12000	100

PIN	Signal	Meaning
3	RxD/TxD-P	Received/sent data, positive, B-cable
5	DGND	Data transmission potential (reference potential to VP)
6	VP	5 V auxiliary voltage output (P5V), max. 50 mA
8	RxD/TxD-N	Received/sent data, negative, A-cable

12 Fiber optics interface (FO port)



WARNING: Danger of eye injuries

During operation, do not look directly into the transmitter diodes or use optical aids to look into the fiberglass! The infrared light is not visible.



Avoid contamination.
Do not remove the dust protection caps until just before the connectors are connected.



When using fiber optic cables, observe the installation guideline
DB GB IBS SYS FOC ASSEMBLY, Order No. 9423439.

FSMA connection (PSI-MOS-PROFIB/FO 660...)

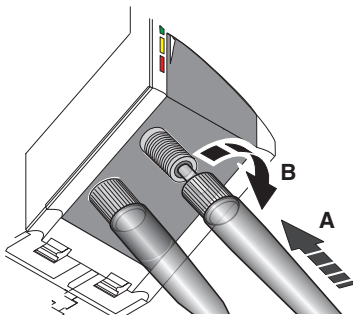

Figure 12 Connecting FSMA connectors

- Connect the FO cable to the FSMA connector for the transmit and receive channel (A).
- Turn the union nut clockwise by hand to tighten (B).

B-FOC (ST®) connection (PSI-MOS-PROFIB/FO 850...)

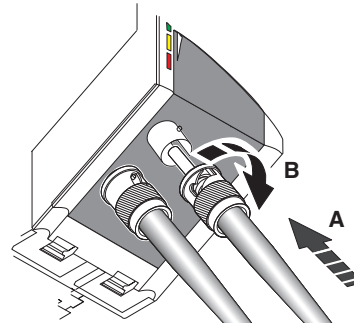

Figure 13 Connecting B-FOC (ST®) connectors

- Connect the FO cable to the B-FOC (ST®) connector for the transmit and receive channel and push the spring mechanism of the connector downward (A).
- Secure the connection with a quarter turn to the right (B).

Coupling the devices

Due to the integrated optical diagnostics, there is no need to measure the path.

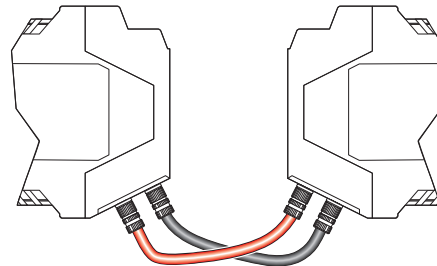

Figure 14 Crossed cables

When connecting two FO converters, note the signal direction of the fiber optics:

- Fiber connection “TD” (transmitter) at device 1
- Fiber connection “RD” (receiver) at device 2



Please note the transmit and receive channel crossover.

Due to different operating wavelengths, PSI-MOS-PROFIB/FO 660... PSI-MOS-PROFIB/FO 850... and PSI-MOS-PROFIB/FO 1300... devices should not be connected directly with one another via fiber optic cables.

13 Switching output



NOTE: Device damage

The maximum capacity of the relay contact is 60 V DC/42 V AC, 0.46 A.

The device is equipped with a floating switching output for error diagnostics (terminals **3** (11) and **4** (12)).

The switch contact opens on the relevant device in the event of the following:

- Supply voltage failure
- Interruption of the fiber optic interface detected
- System reserve of the fiber optic path not reached

The switching output is an N/C contact. It can be connected to a local digital input, e.g. on a PLC, for error detection.

When a topology is used, the individual switching outputs can be connected to separate input points or the individual contacts can be looped through to generate a group message.

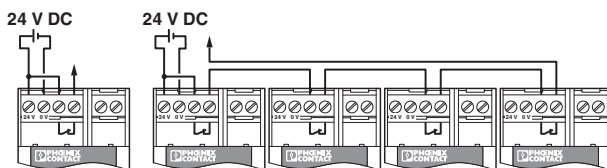

Figure 15 Individual and group message

14 Configuration rules

Data transmission cables and network components lead to signal delays. You must therefore adjust the network parameters using suitable configuration software (e. g. SIMATIC STEP 7®). Take into account the maximum network expansion as well.

The following specifications aid you in the calculation of the required network parameters. These parameters depend on the type of network structure (linear, ring, etc.) as well as the PSI-MOS devices used.

The configuration of network parameters is described using a practical example with STEP 7® software.

The following data is required for configuration:

- Total number of PSI-MOS devices (referred to as "OLM" in STEP 7®)
- Total length of all fiber optic cables



To facilitate the configuration, you will find two different configuration instructions in the following.

Section 14.1 on page 25 describes the **operation of PSI-MOS devices with a 10-pos. DIP switch**.

Section 14.2 on page 28 describes the **operation of PSI-MOS devices with an 8-pos. DIP switch and mixed operation for devices with 8 and 10-pos. DIP switches**.

14.1 Configuring the network parameters (PSI-MOS devices with 10-pos. DIP switch)

Operation in linear, star, and tree structures

In these network structures, calculate with the following formula:

$$T_{\text{slot_Init}} = a + b \times L + 2 \times N$$

with

- $T_{\text{slot_Init}}$ = Minimum slot time in bit periods
- a, b = Length parameter (see table)
- L = Network expansion in km
- N = Number of PSI-MOS devices

Transmission speed [kbps]	a		b
	DP	DP / FMS	
12000	811	811	120
6000	461	461	60
3000	261	261	30
1500	161	991	15
500	111	371	5
187.5	71	371	1.875
93.75	71	211	0.9375
45.45	411	411	0.4545
19.2	71	76	0.192
9.6	71	71	0.096

Operation in a redundant ring

In this network structure, calculate with the following formula:

$$T_{\text{slot_Init}} = a + b \times L + 44 \times N$$

with

- $T_{\text{slot_Init}}$ = Minimum slot time in bit periods
- a, b = Length parameter (see table)
- L = Network expansion in km
- N = Number of PSI-MOS devices

Transmission speed [kbps]	a		b
	DP	DP / FMS	
12000	1651	1651	240
6000	951	951	120
3000	551	551	60
1500	351	2011	30
500	251	771	10
187.5	171	771	3.75
93.75	171	451	1.875
45.45	851	851	0.909
19.2	171	181	0.384
9.6	171	171	0.192

Example

- PROFIBUS DP network with 1.5 Mbps
- Number of FO converters in the ring: 4
- Total length of all fiber optic cables: 4 km

The following steps are required for the configuration of the network parameters:

- Open the "Properties-DP" dialog and click on "Properties".

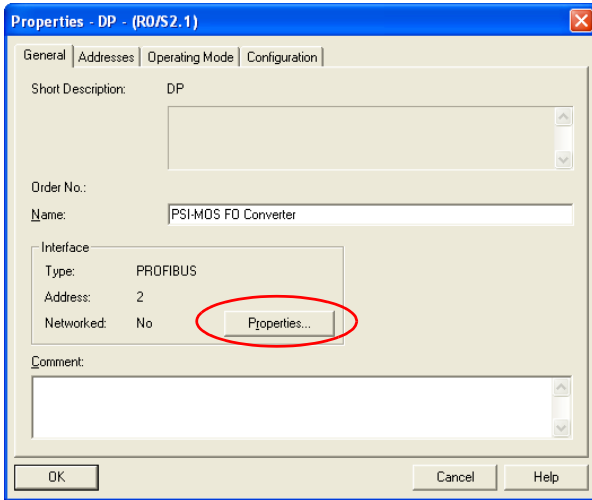

- Switch to the "Cables" tab and activate the "Take into account the following cable configuration" checkbox.
- Enter the number of all the PSI-MOS (OLM) devices used and the total length of all fiber optic cables.
- Close all dialog boxes with "OK".

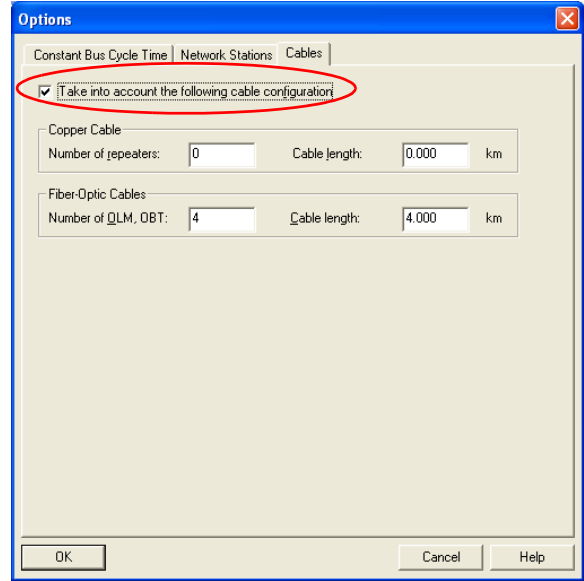

- Select the subnetwork to be configured and click on "Properties".

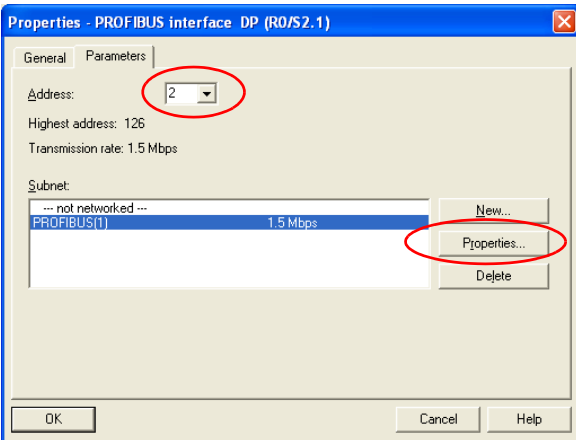

- Switch to the "Network Settings" tab and activate the "User-Defined" profile.
- Click on "Bus Parameters".

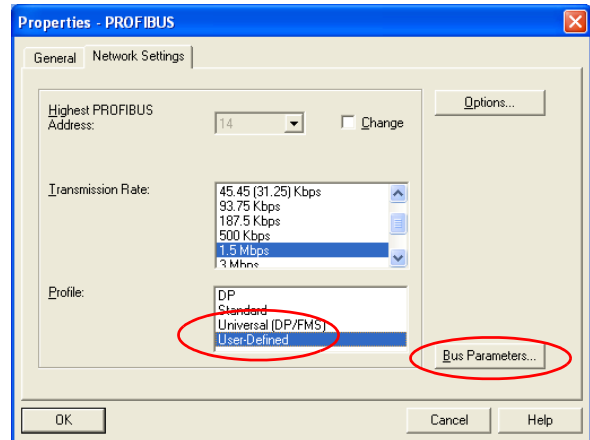

- Switch to the "Network Settings" tab. Increase the highest PROFIBUS address (HSA) by 1. Click on "Options".

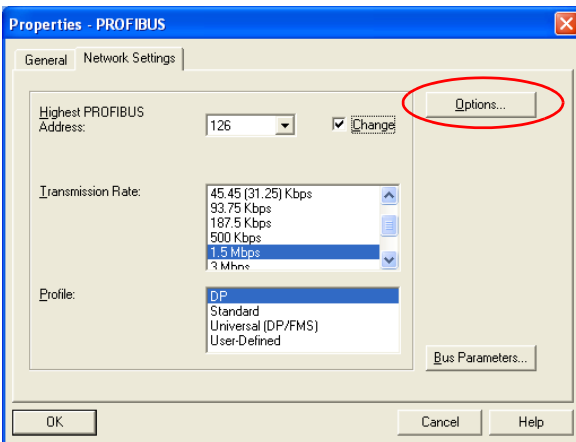

Calculation for this example



The slot time calculation only takes into account the optical network and the electrical connection of bus users over an RS-485 bus segment with a length of maximum 20 m.

Longer RS-485 bus segments must also be included in the calculation, by adding them to the fiber optic cable length.

$$T_{slot_Init} = a + b \times L + 44 \times N$$

$$T_{slot_Init} = 351 + 30 \times 4 + 44 \times 4 = 647$$

The screenshot shows the 'PROFIBUS(1) Bus Parameters' dialog box. The 'Tslot_Init' field is set to 647 t_bit. The 'Gap Factor' is set to 1 and the 'Retry limit' is set to 3. The 'Recalculate' button is highlighted with a red circle. Other parameters include: Max.Tsdr: 150 t_bit, Min.Tsdr: 11 t_bit, Tset: 1 t_bit, Tguir: 0 t_bit, Tslot: 656 t_bit, Tid2: 150 t_bit, Trdy: 11 t_bit, Tid1: 37 t_bit, Ttr: 32251 t_bit (21.5 ms), Ttr typically: 1607 t_bit (1.1 ms), and Watchdog: 67572 t_bit (45.0 ms).

- Enter the calculated value in the input field. Click on “Recalculate”.
- Change the “Gap Factor” to “1” and increase the “Retry limit” parameter to “3”.
- Confirm all dialog boxes with “OK” and load the parameterization to your controller.

Retry limit

In a redundant ring, when an error is detected (e.g. cable break for the optical fiber) PSI-MOS devices require a switch-over time during which correct data transmission is not possible.

In order to ensure error-free bridging for the application, we recommend setting the minimum retry limit in the PROFIBUS master to 3.

Interruption of a fiber optic cable during a message transmission destroys the message. It can no longer be evaluated by the receiver. The PSI-MOS device detects the path fault that has occurred on the basis of missing telegrams.

Up to a total of two telegrams in succession can be destroyed or not transmitted at all before the redundant control system reliably detects the cable break and ensures stable message transmission again.

14.2 Configuring the network parameters (PSI-MOS devices with 8-pos. DIP switch)



The following configuration instructions are also valid for the mixed operation of PSI-MOS devices with 8- and 10-pos. DIP switches. In this case, set DIP switch 9 (COMPATIBILITY) to "ON".

Operation in linear, star, and tree structures

In these network structures, calculate with the following formula:

$$Tslot_Init = a + b \times L + 2 \times N$$

with

- Tslot_Init = Minimum slot time in bit periods
- a, b = Length parameter (see table)
- L = Network expansion in km
- N = Number of PSI-MOS devices

Transmission speed [kbps]	a		b
	DP	DP / FMS	
12000	811	811	120
6000	461	461	60
3000	261	261	30
1500	161	991	15
500	111	371	5
187.5	71	371	1.875
93.75	71	211	0.9375
45.45	411	411	0.4545
19.2	71	76	0.192
9.6	71	71	0.096

Operation in a redundant ring

In this network structure, calculate with the following formula:

$$Tslot_Init = a + b \times L + 4 \times N$$

with

- Tslot_Init = Minimum slot time in bit periods
- a, b = Length parameter (see table)
- L = Network expansion in km
- N = Number of PSI-MOS devices

Transmission speed [kbps]	a		b
	DP	DP / FMS	
1500	311	1971	30
500	211	731	10
187.5	131	731	3.75
93.75	131	411	1.875
45.45	811	811	0.909
19.2	131	141	0.384
9.6	131	131	0.192



For PSI-MOS devices with an 8-pos. DIP switch, the maximum transmission speed in a redundant ring is 1.5 Mbps.

Example

- PROFIBUS DP network with 1.5 Mbps
- Number of FO converters in the ring: 4
- Total length of all fiber optic cables: 4 km

The following steps are required for the configuration of the network parameters:

- Open the "Properties-DP" dialog and click on "Properties".

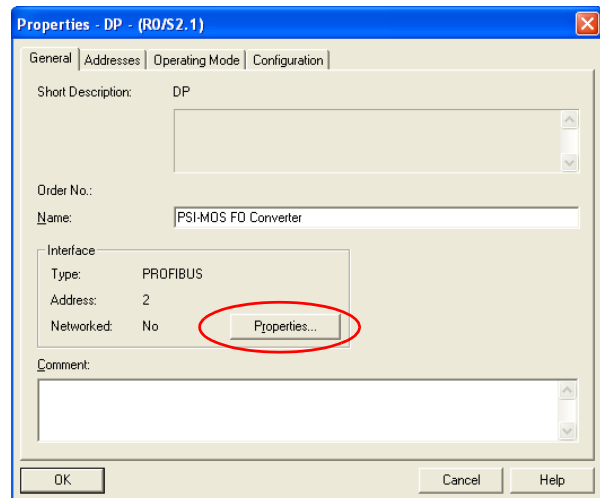

- Select the subnetwork to be configured and click on “Properties”.

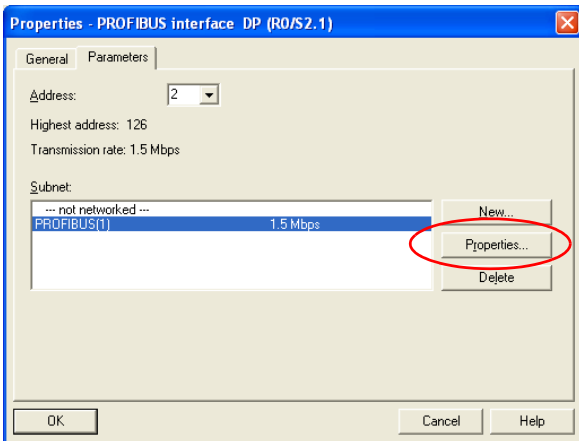

- Switch to the “Network Settings” tab and click on “Options”.

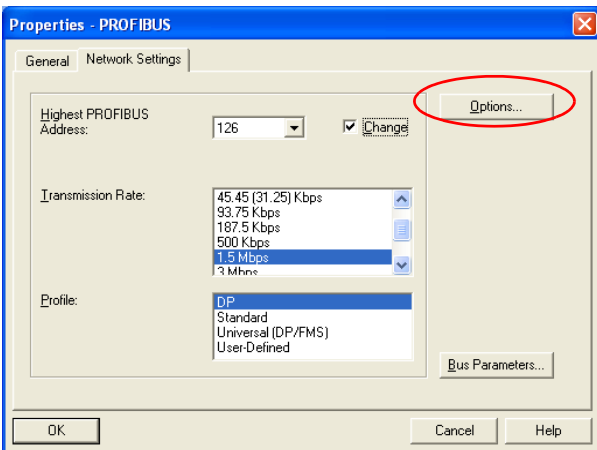

- Switch to the “Cables” tab and activate the “Take into account the following cable configuration” checkbox.
- Enter the number of all the PSI-MOS (OLM) devices used and the total length of all fiber optic cables.
- Close all dialog boxes with “OK”.

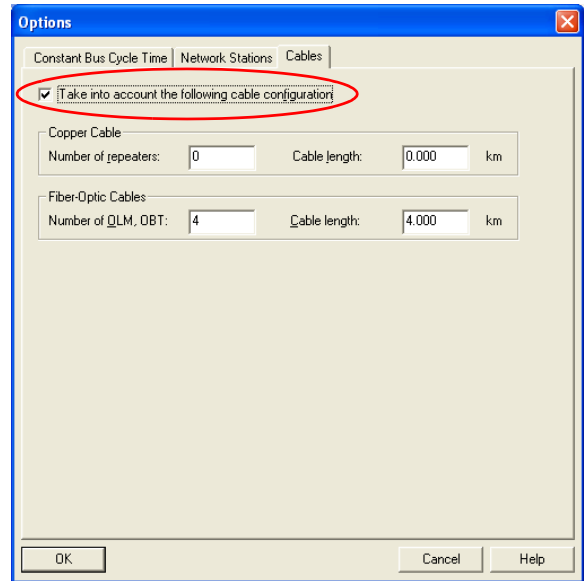

- Switch to the “Network Settings” tab and activate the “User-Defined” profile.
- Click on “Bus Parameters”.

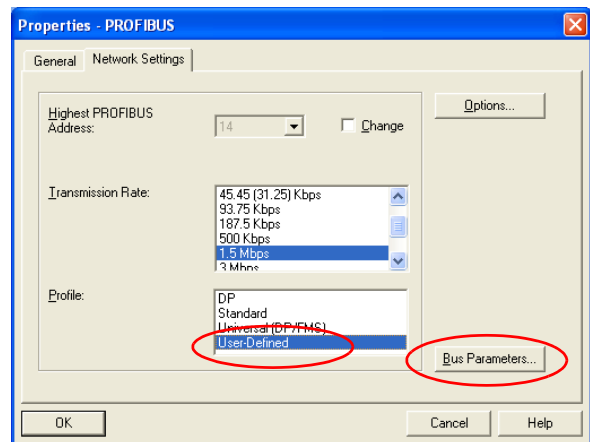

Calculation for this example



The slot time calculation only takes into account the optical network and the electrical connection of bus users over an RS-485 bus segment with a length of maximum 20 m. Longer RS-485 bus segments must also be included in the calculation, by adding them to the fiber optic cable length.



When automatic transmission speed detection is activated, the maximum PROFIBUS slot time (Tslot) must be 100 ms. If the slot time is greater, the devices must be configured to the transmission speed used.

$$Tslot_Init = a + b \times L + 4 \times N$$

$$Tslot_Init = 311 + 30 \times 4 + 4 \times 4 = 447$$

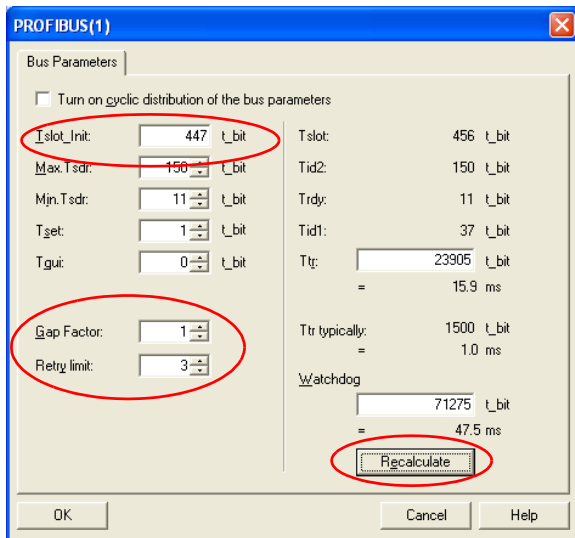

- Enter the calculated value in the input field. Click on "Recalculate".
- Change the "Gap Factor" to "1" and increase the "Retry limit" parameter to "3".
- Confirm all dialog boxes with "OK" and load the parameterization to your controller.

Maximum ring lengths in kilometers for PSI-MOS devices with an 8-pos. DIP switch



For all PSI-MOS devices with an 8-pos. DIP switch, there must be at least three devices in the redundant ring.

For PSI-MOS devices with an 8-pos. DIP switch, please observe the ring lengths in the following table.

For PSI-MOS devices with a 10-pos. DIP switch, there are no restrictions in terms of ring length if DIP switch 9 (COMPATIBILITY) is set to "OFF".

If DIP switch 9 is set to "ON", the values for the total length (in km) specified in the table below apply.

Number of PSI-MOS	Transmission speed (kbps)						
	9.60	19.20	45.45	93.75	187.50	500	1500
2	Not permitted						
3	9.90	9.90	9.90	9.90	9.90	9.90	5.20
4	13.20	13.20	13.20	13.20	13.20	13.20	5.07
6	19.80	19.80	19.80	19.80	19.80	14.40	4.80
8	26.40	26.40	26.40	26.40	26.40	13.60	4.53
10	33.00	33.00	33.00	33.00	33.00	12.80	4.27
12	39.60	39.60	39.60	39.60	32.00	12.00	4.00
14	46.20	46.20	46.20	46.20	29.87	11.20	3.73
16	52.80	52.80	52.80	52.80	27.73	10.40	3.47
18	59.40	59.40	59.40	51.20	25.60	9.60	3.20
20	66.00	66.00	66.00	46.93	23.47	8.80	2.93
22	72.60	72.60	72.60	42.67	21.33	8.00	2.67
24	79.20	79.20	79.20	38.40	19.20	7.20	2.40
26	85.80	85.80	70.41	34.13	17.07	6.40	2.13
28	92.40	92.40	61.61	29.87	14.93	5.60	1.87
30	99.00	99.00	52.81	25.60	12.80	4.80	1.60
32	105.6	104.17	44.00	21.33	10.67	4.00	1.33

Example:

- Number of FO converters in the ring: 6
- Transmission speed: 500 kbps
- Permitted total length according to table: **14.4 km**
- Installed total length FO: 9.98 km - OK
- PSI-MOS devices with 8-pos. DIP switches

Required slot time:

$$Tslot_Init = 211 + 10 \times 9.98 + 4 \times 6 = 335 \text{ bit}$$

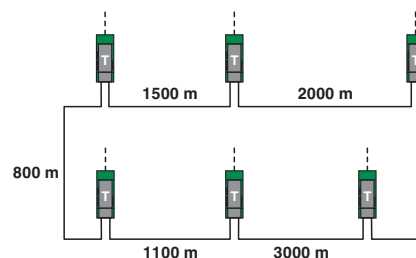

Figure 16 Example of a ring installation