

HR2220V801R-10

PHYSICAL DIMENSIONS:

A	5.59 [.220]	+ 0.51 [.020]
B	5.08 [.200]	+ 0.25 [.010]
C	3.61 [.142]	+ 0.25 [.010]
D	0.76 [.030]	+ 0.25 [.010]

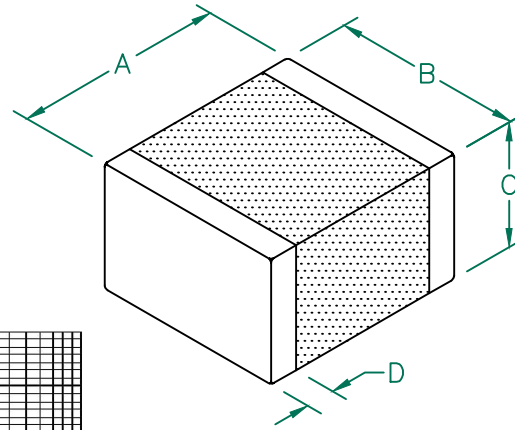

ELECTRICAL CHARACTERISTICS:

Z @ 100 MHz (Ω)	DCR (Ω)	Rated Current
Nominal	800	
Minimum	600	
Maximum	1000	8000 mA

NOTES: UNLESS OTHERWISE SPECIFIED

1. TAPED AND REELED per CURRENT EIA SPECIFICATIONS 13" REELS, 2,000 PCS/REEL.
2. U.S. PATENT 6,249,205B1 IS APPLIED.
3. TERMINATION FINISH IS 100% TIN.
4. COMPONENTS SHOULD BE ADEQUATELY PREHEATED BEFORE SOLDERING.
5. OPERATING TEMPERATURE TEMP: $-55^{\circ}\text{C} \sim +125^{\circ}\text{C}$ (INCLUDING SELF-HEATING)
6. COSMETIC SPECIFICATION REFER TO WI-QA-124.

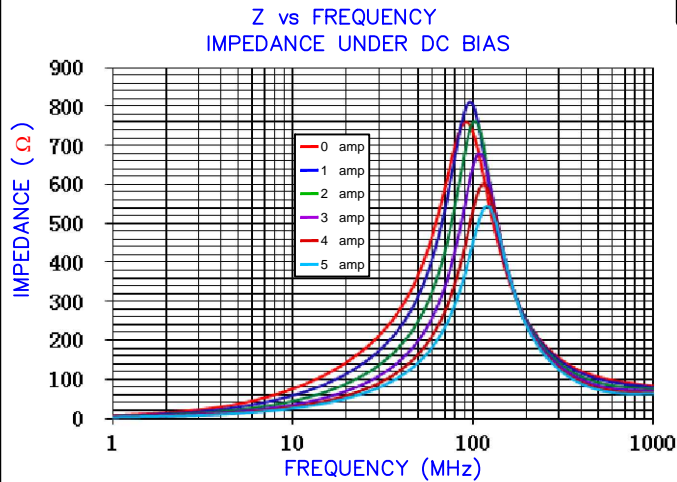

LAND PATTERNS FOR REFLOW SOLDERING

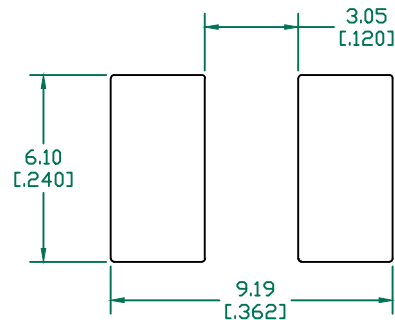

(For wave soldering, add 0.762 [.030] to this dimension.)

RECOMMENDED SOLDERING CONDITIONS

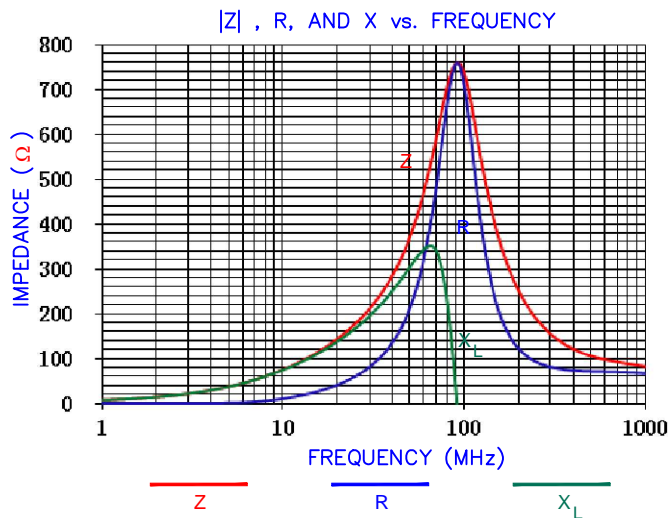
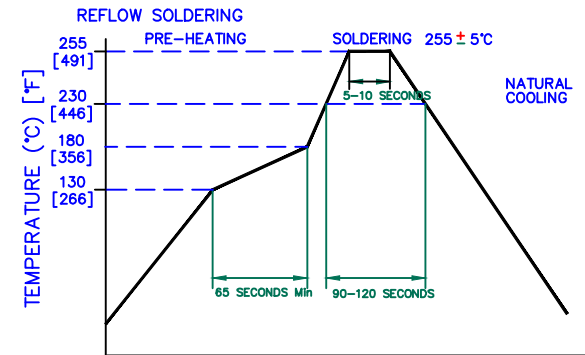

AGILENT E4991A RF Impedance/Material Analyzer
AGILENT 16194A Test Fixture. TEST REF. 3124

RoHS

DIMENSIONS ARE IN mm [INCHES].				This print is the property of Laird Tech. and is loaned in confidence subject to return upon request and with the understanding that no copies shall be made without the written consent of Laird Tech. All rights to design or invention are reserved.	
F	UPDATED NOTE 5	01/12/18	QU	PROJECT/PART NUMBER: HR2220V801R-10	REV F
E	UPDATED NOTES 2	05/15/15	QU		
D	UPDATE Z,R,X AND DC BIAS CURVE CHANGE INNER CONDUCTOR DIMENSION	11/25/14	QU		
C	ADD OPERATING TEMPERATURE UPDATE LAIRD LOGO AND REFLOW CURVE	08/05/13	QU		
B	UPDATE COMPANY LOGO ADD ROHS	02/14/08	JRK		
A	ORIGINAL DRAFT	04/03/04	TMB	DATE: 04/03/04	SCALE: NTS
REV	DESCRIPTION	DATE	INT	CAD # HR2220V801R-10-F	TOOL # -

Laird

PART TYPE:
CO-FIRE

DRAWN BY:
QU

SHEET:
1 of 1