



WINSTAR Display Co.,Ltd.
華凌光電股份有限公司



Winstar Display Co., LTD

華凌光電股份有限公司

WEB: <https://www.winstar.com.tw> E-mail: sales@winstar.com.tw



SPECIFICATION

CUSTOMER : _____

MODULE NO.: WF35UTYAIDNGO#

<p style="text-align: center;">APPROVED BY:</p> <p>(FOR CUSTOMER USE ONLY)</p>	<p>PCB VERSION: _____</p> <p>DATA: _____</p>
---	--

SALES BY	APPROVED BY	CHECKED BY	PREPARED BY
			葉虹蘭
ISSUED DATE: 2020/08/28			

TFT Display Inspection Specification: <https://www.winstar.com.tw/technology/download.html>

Precaution in use of TFT module: <https://www.winstar.com.tw/technology/download/declaration.html>

MODLE NO :

RECORDS OF REVISION			DOC. FIRST ISSUE
VERSION	DATE	REVISED PAGE NO.	SUMMARY
0	2018/01/19		First issue
A	2018/04/25		Modify AC CHARATERISTICS.
B	2018/05/07		Add RGB Interface.
C	2020/08/28		Modify backlight.

Contents

1.Module Classification Information

2.Summary

3.General Specification

4.Absolute Maximum Ratings

5.Electrical Characteristics

6.DC Characteristics

7.AC Characteristics

8.Optical Characteristics

9.Interface

10.Block Diagram

11.Reliability

12.Touch Panel Information

13.Contour Drawing

14.Other

1. Module Classification Information

W F 35 U T Y A I D N G 0 #
 ① ② ③ ④ ⑤ ⑥ ⑦ ⑧ ⑨ ⑩ ⑪ ⑫ ⑬

①	Brand : WINSTAR DISPLAY CORPORATION											
②	Display Type : F→TFT Type, J→Custom TFT											
③	Display Size : 3.5" TFT											
④	Model serials no.											
⑤	Backlight Type :		F→CCFL, White S→LED, High Light White				T→LED, White Z→Nichia LED, White					
⑥	LCD Polarize Type/ Temperature range/ Gray Scale Inversion Direction		A→Transmissive, N.T, IPS TFT C→Transmissive, N. T, 6:00 ; F→Transmissive, N.T,12:00 ; I→Transmissive, W. T, 6:00 K→Transflective, W.T,12:00 L→Transmissive, W.T,12:00 N→Transmissive, Super W.T, 6:00				Q→Transmissive, Super W.T, 12:00 R→Transmissive, Super W.T, O-TFT V→Transmissive, Super W.T, VA TFT W→Transmissive, Super W.T, IPS TFT X→Transmissive, W.T, VA TFT Y→Transmissive, W.T, IPS TFT Z→Transmissive, W.T, O-TFT					
⑦	A : TFT LCD B : TFT+SCREW HOLES+CONTROL BOARD C : TFT+ SCREW HOLES +A/D BOARD D : TFT+ SCREW HOLES +A/D BOARD+CONTROL BOARD E : TFT+ SCREW HOLES +POWER BOARD					F : TFT+CONTROL BOARD G : TFT+ SCREW HOLES H : TFT+D/V BOARD I : TFT+ SCREW HOLES +D/V BOARD J : TFT+POWER BD						
⑧	Resolution:											
	A	128160	B	320234	C	320240	D	480234	E	480272	F	640480
	G	800480	H	1024600	I	320480	J	240320	K	800600	L	240400
	M	1024768	N	128128	P	1280800	Q	480800	R	640320	S	480128
	T	800320	U	8001280	V	176220	W	1280398	X	1024250	Y	1920720
	Z	800200	2	1024324	3	7201280	4	19201200	5	1366768	6	1280320
⑨	D: Digital L : LVDS M:MIPI											
⑩	Interface:											
	N	Without control board			A	8Bit		B	16Bit		H	HDMI
	I	I2C Interface			R	RS232		S	SPI Interface		U	USB
⑪	TS:											
	N	Without TS			T	Resistive touch panel			C	Capacitive touch panel (G-F-F)		
	G	Capacitive touch panel (G-G)					C1	Capacitive touch panel (G-F-F)+OCA				
	C2	Capacitive touch panel (G-F-F)+OCR					G1	Capacitive touch panel (G-G)+OCA				
	G2	Capacitive touch panel (G-G)+OCR					B	CTP+GG+USB				
⑫	Version: X:Raspberry pi											
⑬	Special Code		#:Fit in with ROHS directive regulations									

2.Summary

TFT 3.5 is a IPS transmissive type color active matrix TFT liquid crystal display that use amorphous silicon TFT as switching devices. This module is a composed of a TFT_LCD module, It is usually designed for industrial application and this module follows RoHs.

3.General Specifications

Item	Dimension	Unit
Size	3.5	inch
Dot Matrix	320 x RGBx 480(TFT)	dots
Module dimension	68.7 (W) x 95.6 (H) x 4.61(D)	mm
Active area	48.96 x 73.44	mm
LCD type	TFT, Normally Black, Transmissive	
View Direction	Wide View	
Aspect Ratio	Portrait	
TFT Driver IC	ILI9488 or Equivalent	
TFT Interface	MCU 8/16/18-bit, 3-SPI ,RGB interface+3-SPI	
Backlight Type	LED,Normally White	
With /Without TP	With CTP	
CTP IC	GT911 or Equivalent	
CTP Interface	I2C	
CTP FW Version	0x95	
Surface	Glare	

*Color tone slight changed by temperature and driving voltage.

4. Absolute Maximum Ratings

Item	Symbol	Min	Typ	Max	Unit
Operating Temperature	TOP	-20	—	+70	°C
Storage Temperature	TST	-30	—	+80	°C

Note: Device is subject to be damaged permanently if stresses beyond those absolute maximum ratings listed above

1. Temp. $\leq 60^{\circ}\text{C}$, 90% RH MAX. Temp. $> 60^{\circ}\text{C}$, Absolute humidity shall be less than 90% RH at 60°C

5. Electrical Characteristics

5.1. Operating conditions:

Item	Symbol	Condition	Min	Typ	Max	Unit
Supply Voltage for digital	IOVCC	—	—	1.8/2.8	3.3	V
Supply Voltage For Touch Logic	VDDT	—	2.8	—	3.3	V
Supply Voltage for analog	VCI	—	—	2.8	3.3	V
Power Supply for Current	ICC	IOVCC=VCI =VCC=3.3V	—	13.6	—	mA

5.2. LED driving conditions

Parameter	Symbol	Min	Typ	Max	Unit	Remark
LED current	—	—	160	—	mA	—
LED voltage	LEDA	2.7	3.2	3.4	V	Note 1
LED Life Time	—	—	50000	—	Hr	Note 2,3

Note 1 : There are 1 Groups LED

Note 2 : Ta = 25°C

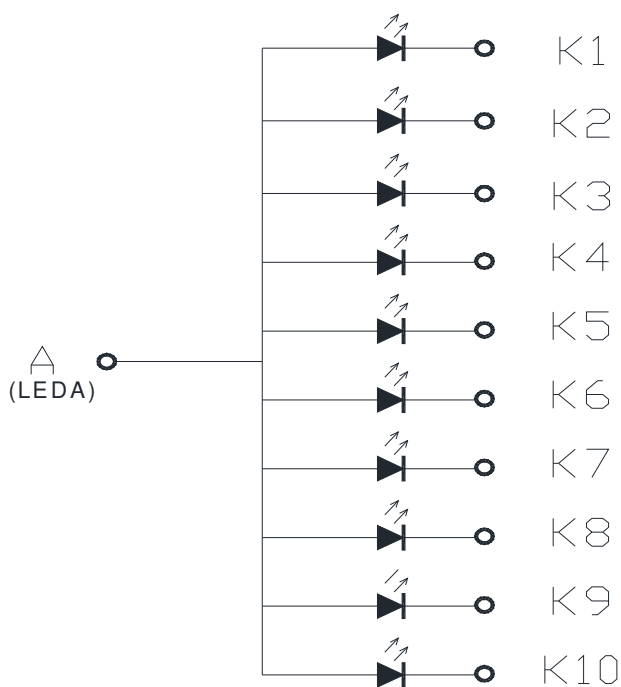

(K1~K10 connector to LEDK)

Note 3 : Brightness to be decreased to 50% of the initial value

6.DC CHARATERISTICS

Parameter	Symbol	Rating			Unit	Condition
		Min	Typ	Max		
Low level input voltage	V_{IL}	0	-	0.2VCC	V	
High level input voltage	V_{IH}	0.8VCC	-	VCC	V	

7.AC CHARACTERISTICS

7.1. DBI Type C Option 1 (3-Line Serial Interface)

The 3-line/9-bit serial bus interface of the ILI9488 can be used by setting external pin IM [2:0] as 101. Figure 1 describes an interface with 8080 MCU system interface.

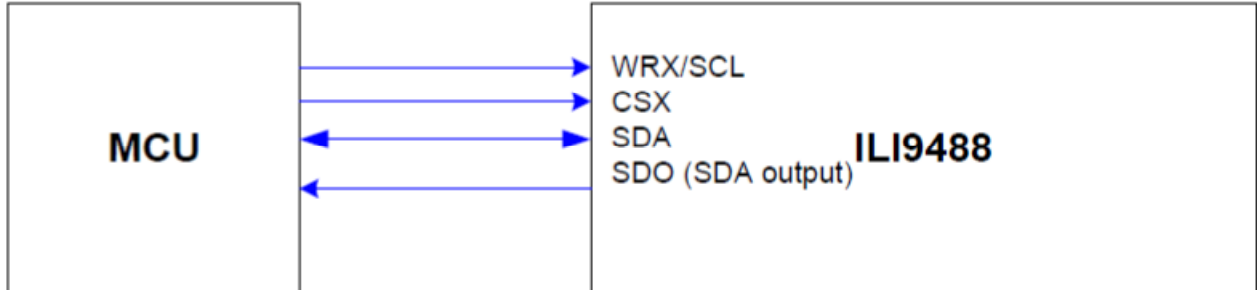

Figure 1: 3-Line Serial Interface

The available display data formats are:

*8 colors, RGB 1, 1, 1 bits input (set Standard Command 3Ah, DBI [2:0] as 001)

*262K-Colors, RGB 6, 6, 6 bits input data (set Standard Command 3Ah, DBI [2:0] as 110)

7.1.1 SPI Data for 3-bit/pixel (RGB 1-1-1 Bits Input), 8-color

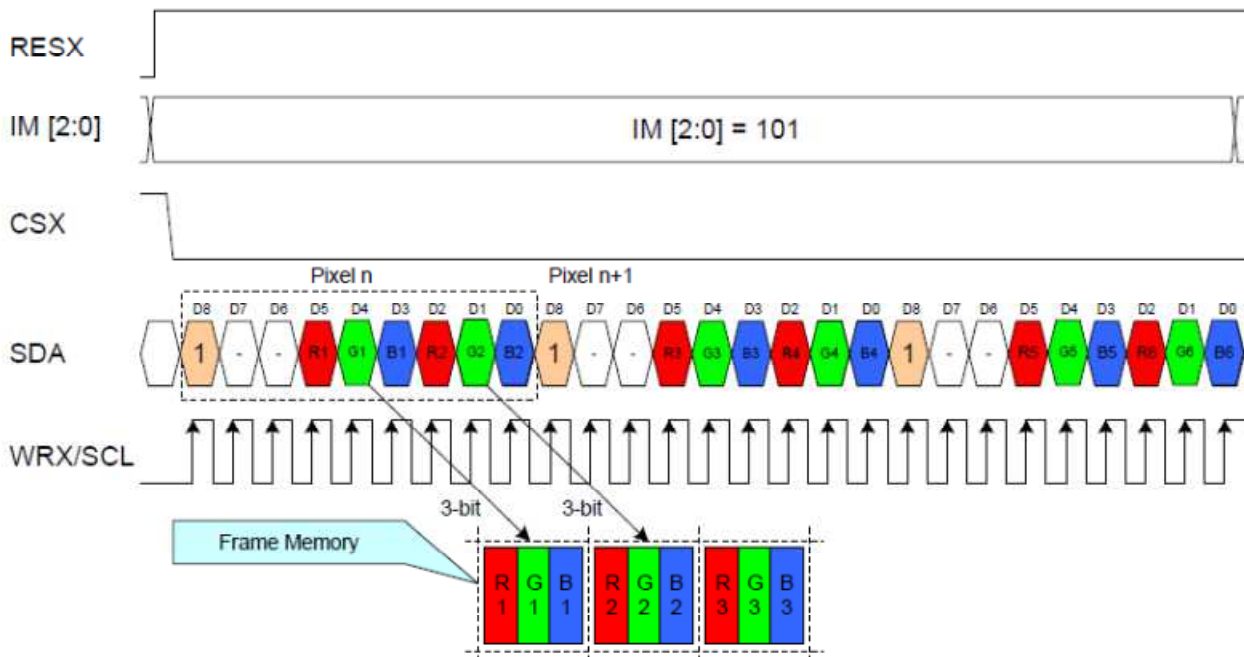

Figure 2: SPI Data for 3 bit/pixel (RGB 1-1-1 Bits Input), 8-color

Notes:

1. One pixel data contains 3-bit color depth information.

7.1.2. SPI Data for 18-bit/pixel (RGB 6-6-6 Bits Input), 262K-color

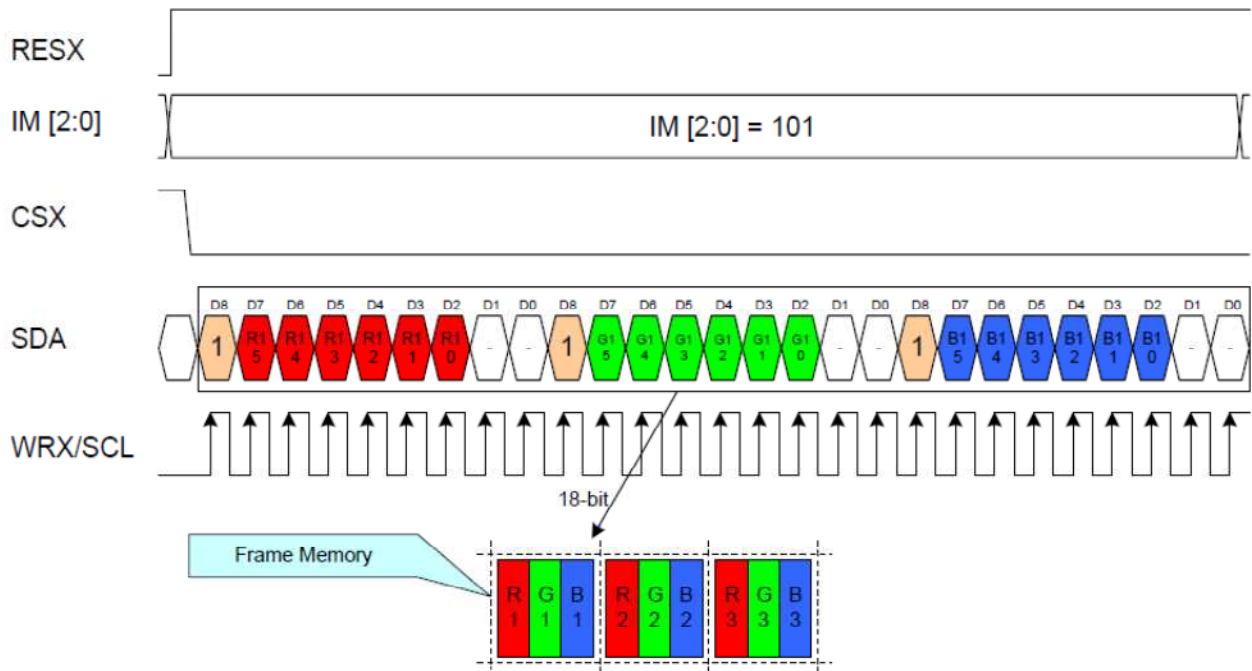

Figure 3: SPI Data for 18-bit/pixel (RGB 6-6-6 Bits Input), 262K-color

Notes:

1. One pixel data contains 18-bit color depth information.
2. The most significant bits are: R x 5, G x 5, and B x 5.
3. The least significant bits are: R x 0, G x 0, and B x 0.

Read data through 3-line SPI mode

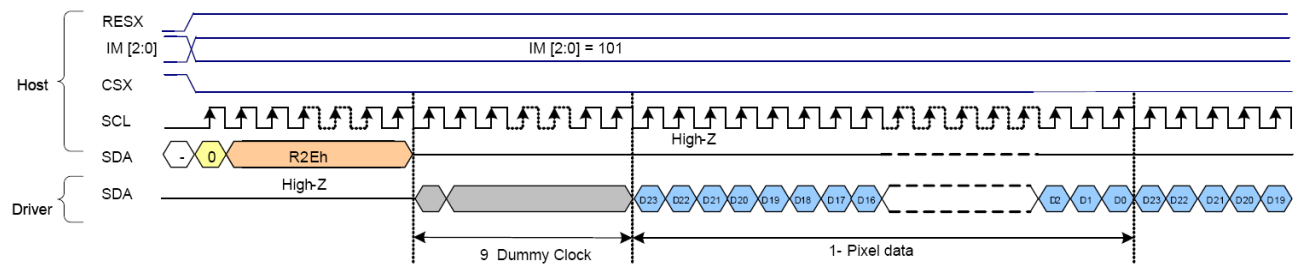

Figure 4: 3-Line SPI Mode Read Data

Note: „-“ = void

7.2. 8-bit Parallel MCU Interface

The DBI TYPE B 8-bit parallel bus interface of the ILI9488 is used by setting the external pin IM [2:0] as 011. Figure 5 shows this system interface.

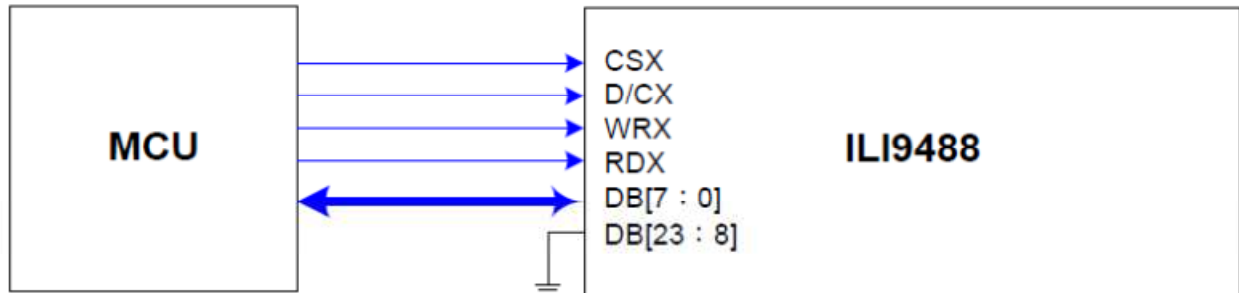

Figure 5: 8-bit Parallel MCU Interface

The available display data formats are:

*65K-Colors, RGB 5, 6, 5 bits input data (set Standard Command 3Ah, DBI [2:0] as 101)

*262K-Colors, RGB 6, 6, 6 bits input data (set Standard Command 3Ah, DBI [2:0] as 110)

7.2.1. 8-bit Data Bus for 16-bit/pixel (RGB 5-6-5 Bits Input), 65K-color

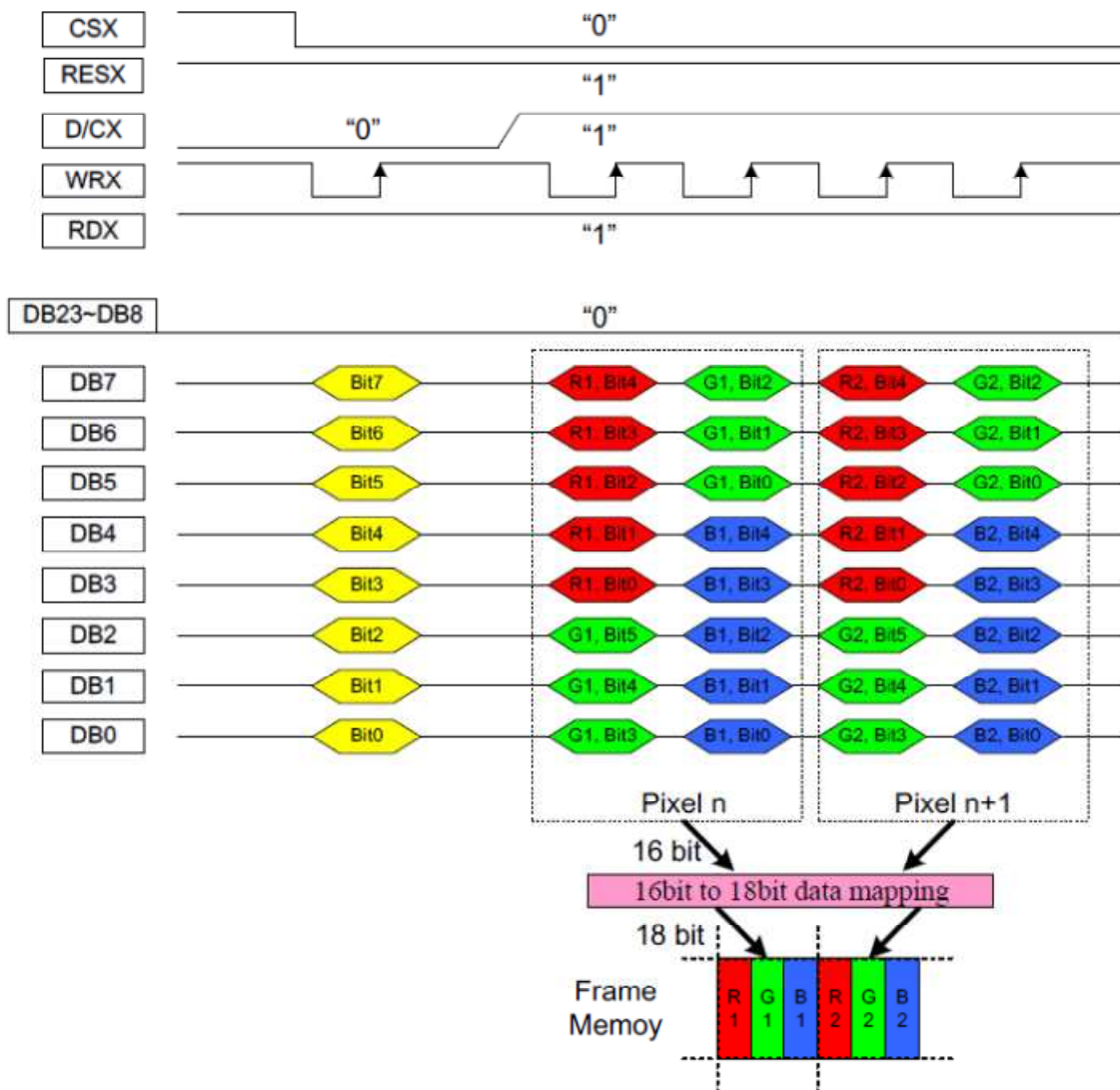

Figure 6: 8-bit Data Bus for 16-bit/pixel (RGB 5-6-5 Bits Input), 65K-color

Notes:

1. The data order is as follows: MSB = DB7, LSB = DB0, and picture data is MSB = Bit 5, LSB = Bit 0 for Green data, and MSB = Bit 4, LSB = Bit 0 for Red and Blue data.
2. 2-times transfer is used to transmit 1 pixel data to the 16-bit color depth information.

7.2.2. 8-bit Data Bus for 18-bit/pixel (RGB 6-6-6 Bits Input), 262K-color

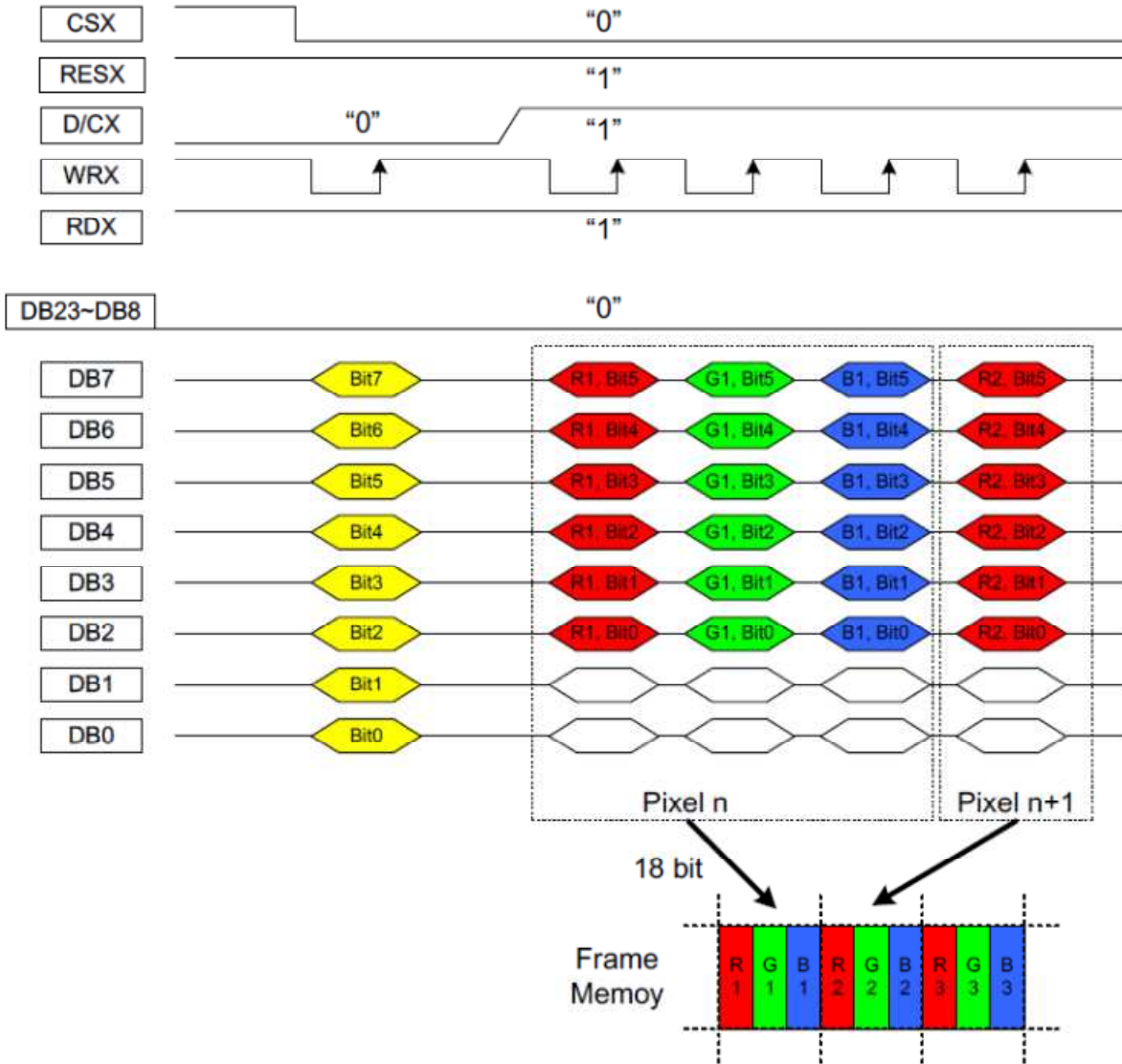

Figure 7: 8-bit Data Bus for 18-bit/pixel (RGB 6-6-6 Bits Input), 262K-color

Notes:

1. The data order is as follows: MSB = DB7, LSB = DB0, and picture data is MSB = Bit 5, LSB = Bit 0 for Green, Red and Blue data.
2. 3-times transfer is used to transmit 1 pixel data to the 18-bit color depth information.

7.3. 16-bit Parallel MCU Interface

The 8080-system 16-bit parallel bus interface of the ILI9488 can be used by setting external pin IM [2:0] as 010.

Figure 8 shows this system interface.

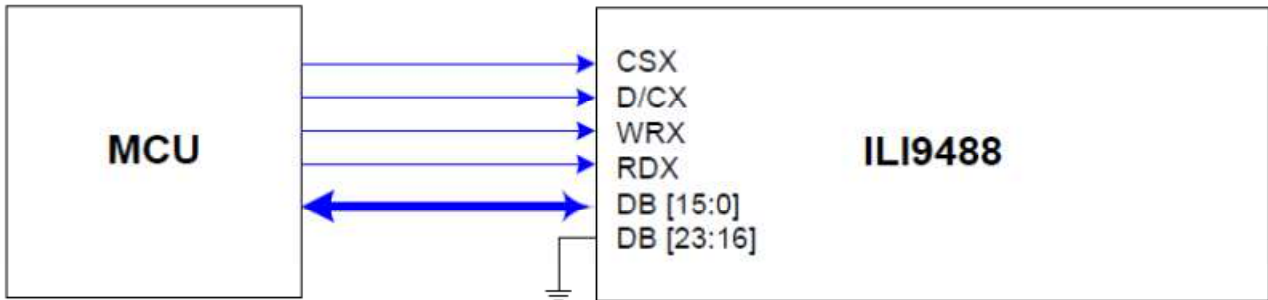

Figure 8: 16-bit Parallel MCU Interface

The available display data formats are:

65K-Colors, RGB 5, 6, 5 bits input data (set Standard Command 3Ah, DBI [2:0] as 101)

262K-Colors, RGB 6, 6, 6 bits input data (set Standard Command 3Ah, DBI [2:0] as 110)

7.3.1 16-bit Data Bus for 16-bit/pixel (RGB 5-6-5 Bits Input), 65K-color

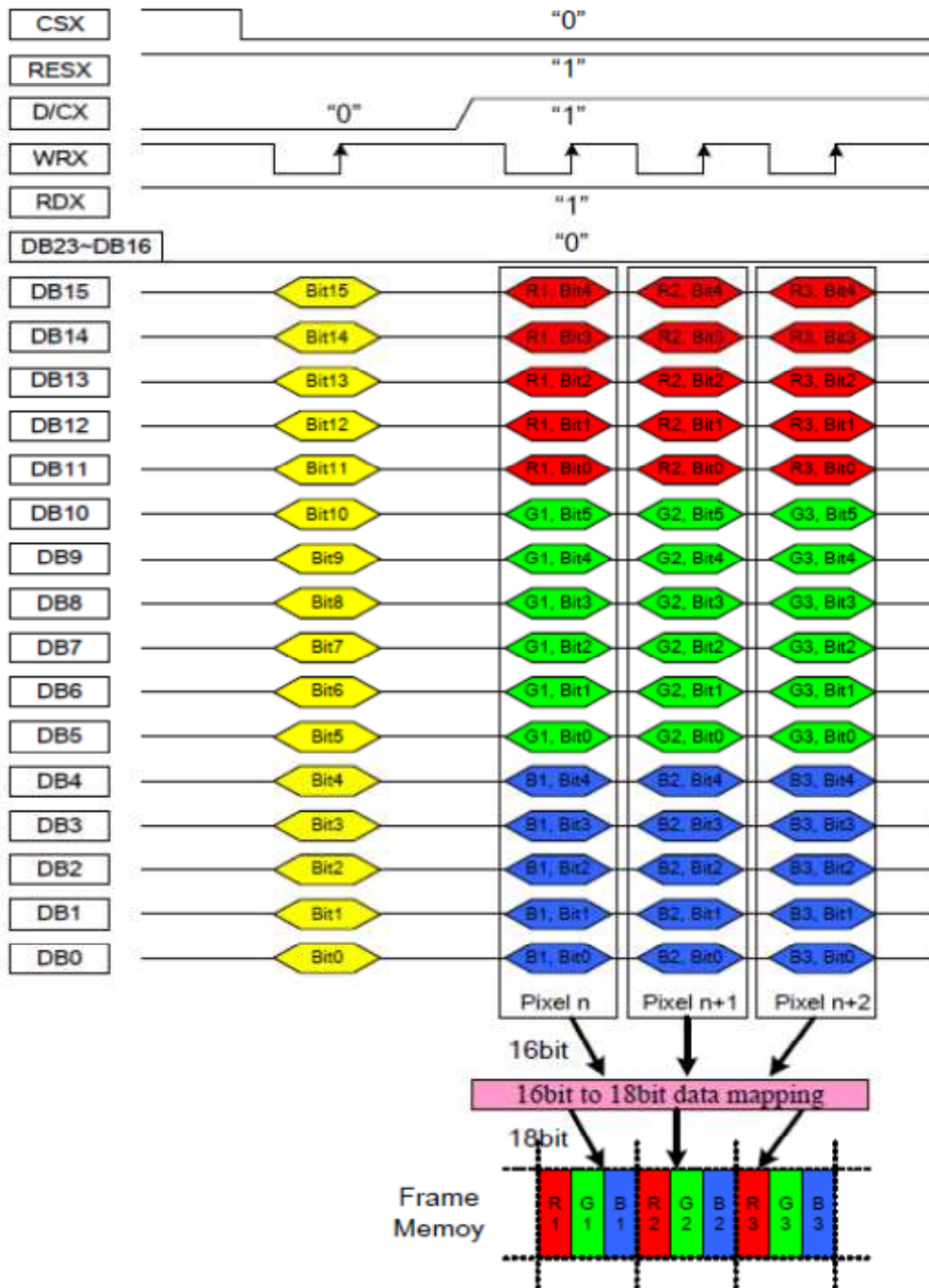

Figure 9: 16-bit Data Bus for 16-bit/pixel (RGB 5-6-5 Bits Input), 65K-color

Notes:

1. The data order is as follows: MSB = DB15, LSB = DB0, and picture data is MSB = Bit 5, LSB = Bit 0 for Green data, and MSB = Bit 4, LSB = Bit0 for Red and Blue data.
2. 1-time transfer is used to transmit 1 pixel data to the 16-bit color depth information.

7.3.2 16-bit Data Bus for 18-bit/pixel (RGB 6-6-6 Bits Input), 262K-color

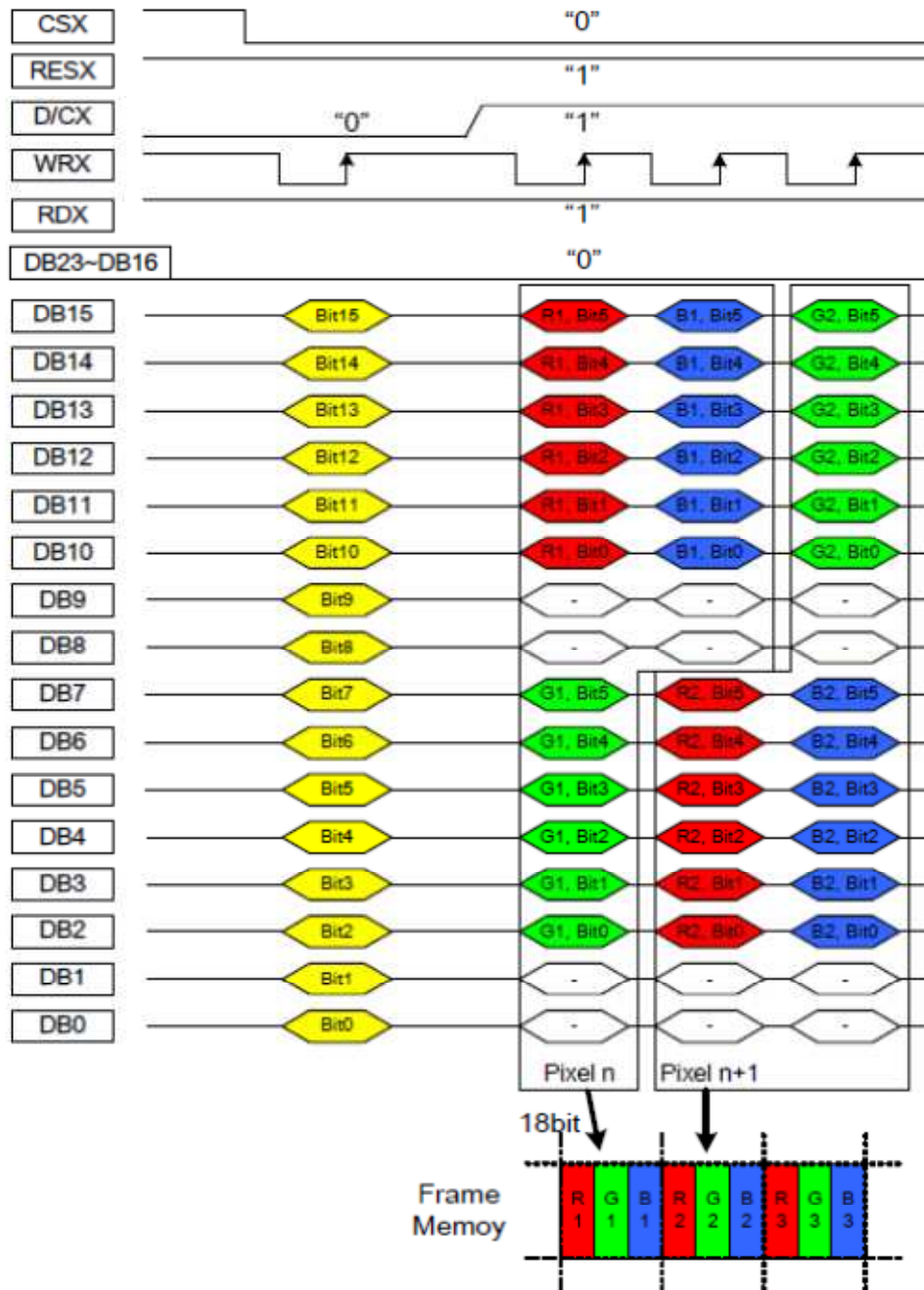

Figure 10: 16-bit Data Bus for 18-bit/pixel (RGB 6-6-6 Bits Input), 262K-color

Notes:

1. The data order is as follows: MSB = DB15, LSB = DB0, and picture data is MSB = Bit 5, LSB = Bit 0 for Green, Red and Blue data.
2. 3-times transfer is used to transmit 2 pixel data to the 18-bit color depth information.

7.4. 18-bit Parallel MCU Interface

The 8080-system 18-bit parallel bus interface of the ILI9488 can be used by setting external pin IM [2:0] as 000.

Figure 11 shows this system interface.

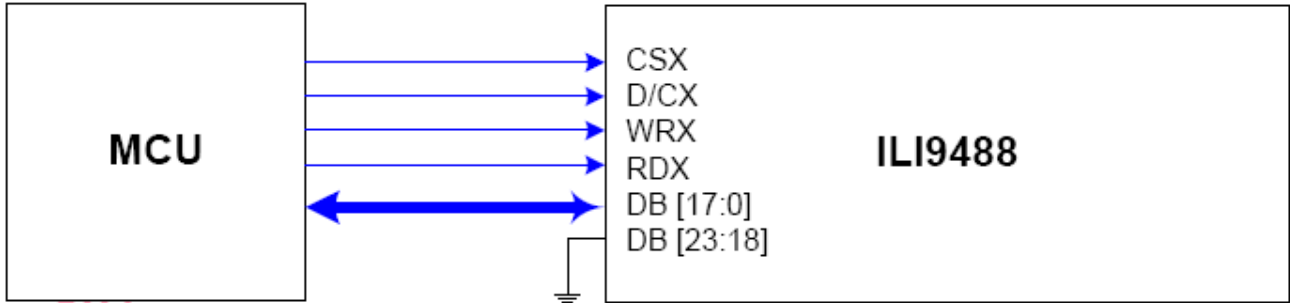

Figure 11: 18-bit Parallel MCU Interface

The available display data formats is:

262K-Colors, RGB 6, 6, 6 bits input data (set Standard Command 3Ah, DBI [2:0] as 110)

7.4.1 18-bit Data Bus for 18-bit/pixel (RGB 6-6-6 Bits Input), 262K-color

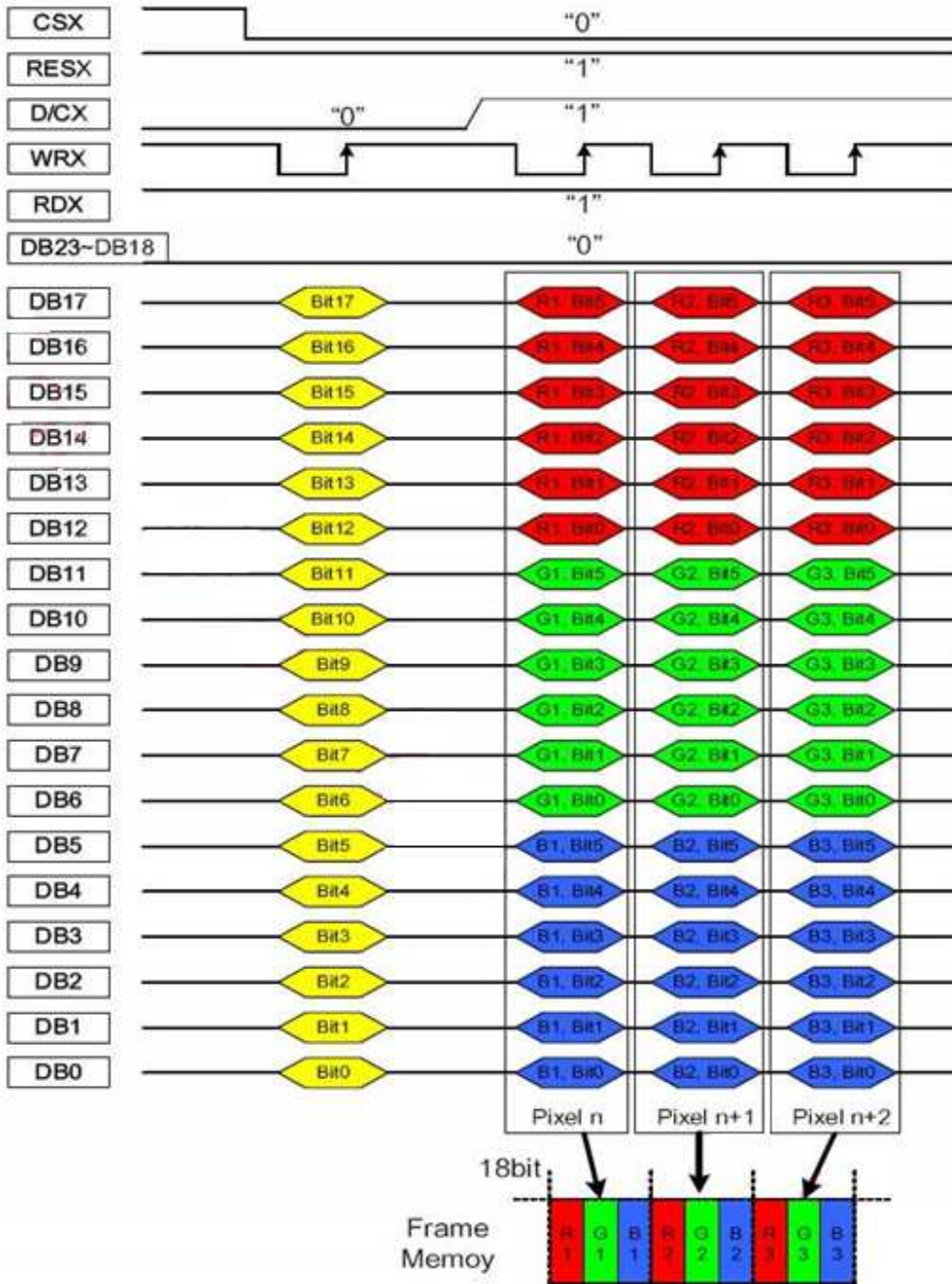

Figure 12: 18-bit Data Bus for 18-bit/pixel (RGB 6-6-6 Bits Input), 262K-color

Notes:

1. The data order is as follows: MSB = DB17, LSB = DB0, and picture data is MSB = Bit 5, LSB = Bit 0 for Green, Red and Blue data.
2. 1-times transfer is used to transmit 1 pixel data to the 18-bit color depth information.

7.5. DPI (RGB Interface)

The DPI can display moving pictures by two ways: rewrite into the GRAM and transmit directly to the shift register. The selection is set by the register BPGRAM (bypass GRAM) and RM bit. The RM bit selects an interface for the access operation of the Frame Memory. For the DPI, RM should be set as 1.

BPGRAM	Display Data Path
1	Direct to shift register
0	Write into Memory
RM	Interface for RAM access
0	System interface
1	RGB interface

The DM bit selects the clock operation mode. It allows switching between display operations in synchronization with the internal oscillation clock. If DM=1, the external DOTCLK cannot be stopped unless it enters the Sleep-In mode.

DM	RGB Interface Operating Clock Selection
0	Internal system clock
1	RGB interface (DOTCLK)

7.5.1 RGB Interface Selection

The DPI can be selected by the RCM bit. When the RCM is set to 0, the DE mode is selected by VSYNC, HSYNC, DOTCLK, ENABLE, and DB[17:0] (or DB[15:0]) pins.

When RCM is set to 1, the SYNC mode is selected by VSYNC, HSYNC, DOTCLK, and DB[17:0] (or DB[15:0]) pins. It supports several pixel formats that can be selected by DPI[2:0] bits in Pixel Format Set (R3Ah) command. The selection of a given interface is done by DPI[2:0], as shown in Table 1 and Figure 13.

Table 1: DPI Interface Selection

RCM	DPI [2:0]			RGB Interface Mode	RGB Mode	Used Pins
0	1	1	0	18-bit RGB interface (262K colors)	DE Mode Valid data is determined by the ENABLE signal.	VSYNC, HSYNC, ENABLE, DOTCLK, DB [17 :0]
0	1	0	1	16-bit RGB interface (65K colors)		VSYNC, HSYNC, ENABLE, DOTCLK, DB [15 :0]
1	1	1	0	18-bit RGB interface (262K colors)	SYNC Mode In the SYNC mode, ENABLE signal is ignored; blanking porch is determined by B5h command.	VSYNC, HSYNC, DOTCLK, DB [17:0]
1	1	0	1	16-bit RGB interface (65K colors)		VSYNC, HSYNC, DOTCLK, DB [15:0]

18-bit DPI interface connection (DB [17:0] is used): set pixel format DPI [2:0] as 110

DB23	DB22	DB21	DB20	DB19	DB18	DB17	DB16	DB15	DB14	DB13	DB12	DB11	DB10	DB9	DB8	DB7	DB6	DB5	DB4	DB3	DB2	DB1	DB0
						R[5]	R[4]	R[3]	R[2]	R[1]	R[0]	G[5]	G[4]	G[3]	G[2]	G[1]	G[0]	B[5]	B[4]	B[3]	B[2]	B[1]	B[0]

16-bit DPI interface connection (DB [15:0] is used): set pixel format DPI [2:0] as 101

DB23	DB22	DB21	DB20	DB19	DB18	DB17	DB16	DB15	DB14	DB13	DB12	DB11	DB10	DB9	DB8	DB7	DB6	DB5	DB4	DB3	DB2	DB1	DB0
								R[4]	R[3]	R[2]	R[1]	R[0]	G[5]	G[4]	G[3]	G[2]	G[1]	G[0]	B[4]	B[3]	B[2]	B[1]	B[0]

Figure 13: RGB Interface 18/16 Pixel Format Selection

The Pixel clock (DOTCLK) runs all the time without stop. It is used to enter VSYNC, HSYNC, ENABLE and DB[17:0] (or DB[15:0]) states when there is a rising edge of the DOTCLK. The DOTCLK cannot be used as the internal clock for other functions of the display module.

Vertical synchronization (VSYNC) is used to indicate when a new frame of the display is received. This is low enable and its state is read to the display module by a rising edge of the DOT CLK signal.

Horizontal synchronization (HSYNC) is used to indicate when a new line of the frame is received. This is low enable and its state is read to the display module by a rising edge of the DOT CLK signal.

Data Enable(ENABLE) is used to indicate when the RGB information that should be transferred in the display is received. This is a high enable, and its state is read to the display module by a rising edge of the DOTCLK signal. DB[17:0] (or DB[15:0]) is used to indicate what is the information of the image that is transferred on the display (when ENABLE = 0 (low) and there is a rising edge of DOTCLK). DB[17:0] (or DB[15:0]) can be 0 (low) or 1 (high). These lines are read by a rising edge of the DOT CLK signal. In RGB interface modes, the input display data is written to GRAM first then outputs the corresponding source voltage according to the gray data from GRAM.

7.5.2 RGB Interface Timing

DPI Parameters Setting(BYPASS bit = 0)

Parameters	Symbols	Min.	Typ.	Max.	Units
Horizontal Synchronization	H_Low	3	-	H_Low < HBP	DOTCLK
Horizontal Back Porch	HBP	3	-	192	DOTCLK
Horizontal Front Porch	HFP	3	-	255	DOTCLK
Horizontal Address	HACT	-	320	-	DOTCLK
Horizontal Frequency		-	-	33	KHz
Vertical Synchronization	V_Low	1	-	V_Low < VBP	Line
Vertical Back Porch	VBP	2	-	V_Low+VBP+VFP < 32	Line
Vertical Front Porch	VFP	2	-		Line
Vertical Address	VACT	-	480	-	Line
Vertical Frequency		60	-	70	Hz
DOTCLK cycle		100	-	50	ns
DOTCLK Frequency		10	-	20	MHz

DPI Parameters Setting(BYPASS bit = 1)

Parameters	Symbols	Min.	Typ.	Max.	Units
Horizontal Synchronization	H_Low	3	-	H_Low < HBP	DOTCLK
Horizontal Back Porch	HBP	20	-	192	DOTCLK
Horizontal Front Porch	HFP	70	-	255	DOTCLK
Horizontal Address	HACT	-	320	-	DOTCLK
Horizontal Frequency		-	-	33	KHz
Vertical Synchronization	V_Low	1	-	V_Low < VBP	Line
Vertical Back Porch	VBP	2	-	V_Low+VBP+VFP < 32	Line
Vertical Front Porch	VFP	2	-		Line
Vertical Address	VACT	-	480	-	Line
Vertical Frequency		60	-	70	Hz
DOTCLK cycle		83.3	-	50	ns
DOTCLK Frequency		12	-	20	MHz

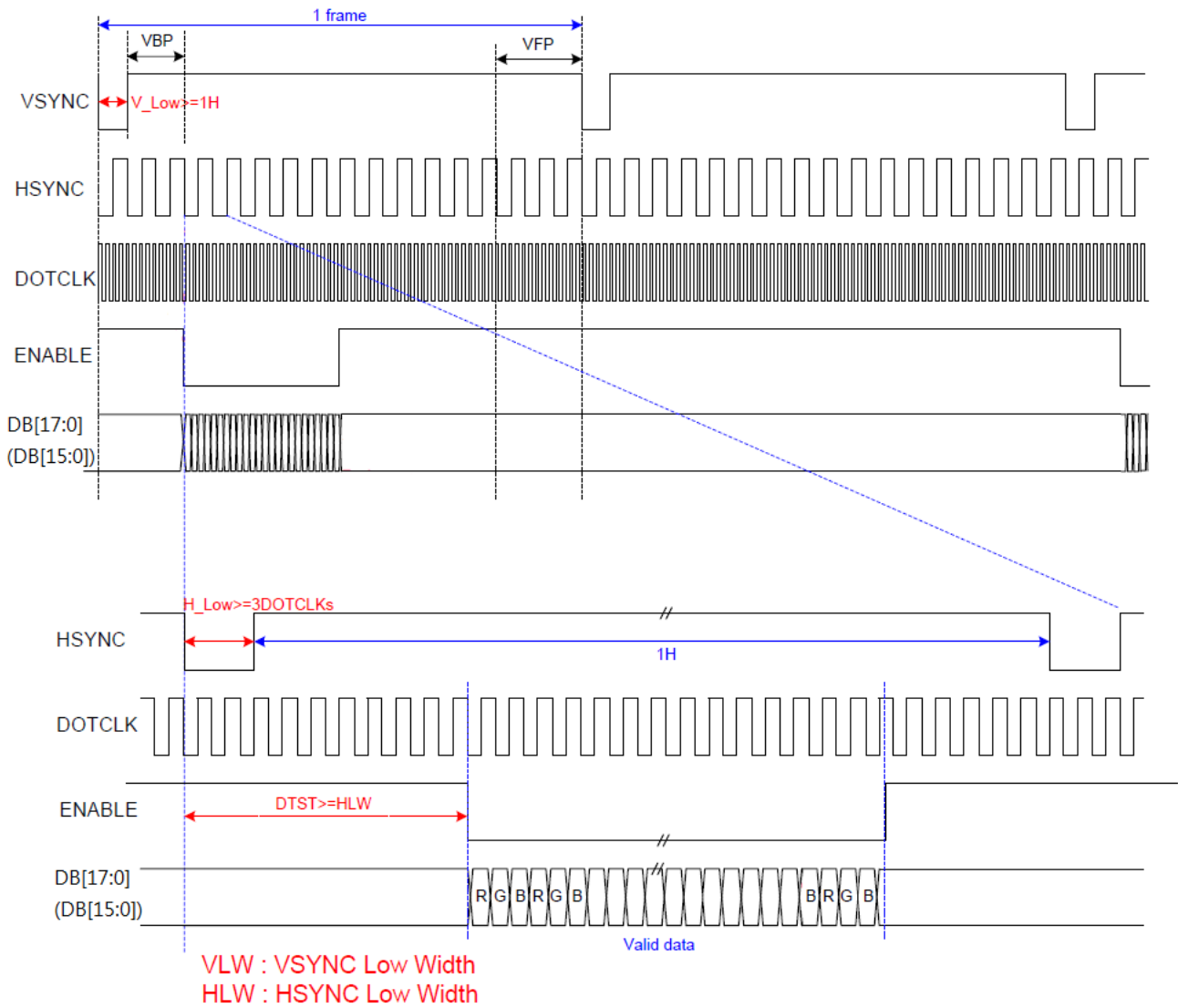

Figure 14: RGB Interface Timing Diagram

7.6. Other command, display data format..., Please reference the ILI9488 Spec

8. Optical Characteristics

Item	Symbol	Condition.	Min	Typ.	Max.	Unit	Remark	
Response time	Tr	$\theta=0^\circ$ 、 $\Phi=0^\circ$	-	30	-	.ms	Note 3	
	Tf							
Contrast ratio	CR	At optimized viewing angle	-	700	-	-	Note 4	
Color Chromaticity	White	Wx	$\theta=0^\circ$ 、 $\Phi=0$	0.26	0.31	0.36	Note 2,6,7	
		Wy		0.28	0.33	0.38		
Viewing angle	Hor.	Θ_R	$CR \geq 10$	-	80	-	Deg.	Note 1
		Θ_L		-	80	-		
	Ver.	Φ_T		-	80	-		
		Φ_B		-	80	-		
Brightness	-	-	400	500	-	cd/m ²	Center of display	
Uniformity	(U)	-	75	-	-	%	Note5	

Ta=25±2°C (ILED=160mA)

Note 1: Definition of viewing angle

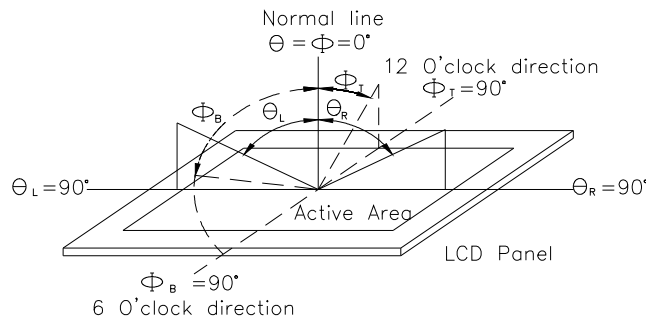

Fig 8.1. Definition of viewing angle

Note 2: Test equipment setup:

After stabilizing and leaving the panel alone at a driven temperature for 10 minutes, the measurement should be executed. Measurement should be executed in a stable, windless, and dark room. Optical specifications are measured by Topcon BM-7orBM-5 luminance meter 1.0° field of view at a distance of 50cm and normal direction.

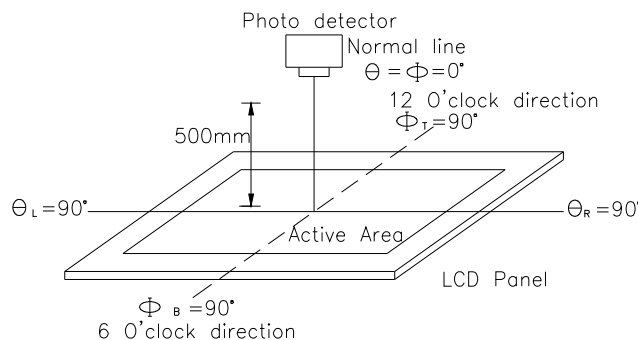
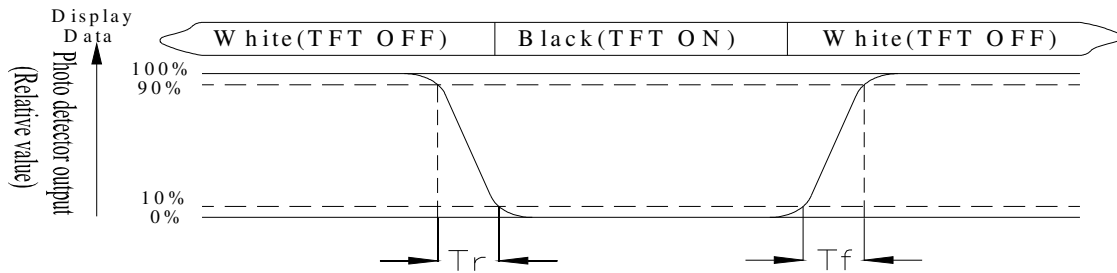

Fig 8.2. Optical measurement system setup

Note 3: Definition of Response time:

The response time is defined as the LCD optical switching time interval between “White” state

and “Black” state. Rise time, T_r , is the time between photo detector output intensity changed from 90% to 10%. And fall time, T_f , is the time between photo detector output intensity changed from 10% to 90%



Note 4: Definition of contrast ratio:

The contrast ratio is defined as the following expression.

$$\text{Contrast ratio (CR)} = \frac{\text{Luminance measured when LCD on the "White" state}}{\text{Luminance measured when LCD on the "Black" state}}$$

Note 5: Definition of Luminance Uniformity

Active area is divided into 9 measuring areas (reference the picture in below). Every measuring point is placed at the center of each measuring area.

Luminance Uniformity (U) = $L_{\min}/L_{\max} \times 100\%$

L = Active area length

W = Active area width

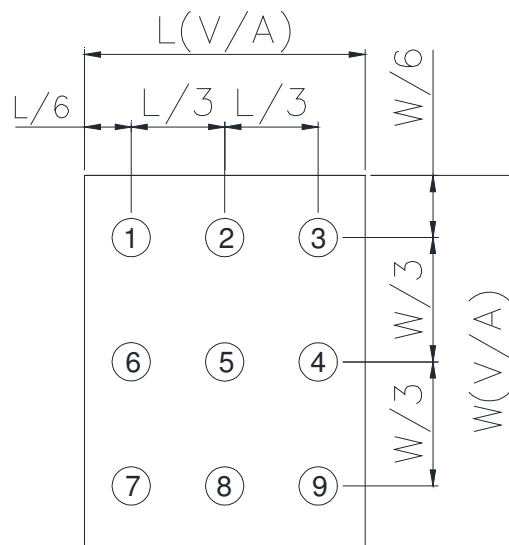

Fig 8.3. Definition of uniformity

Note 6: Definition of color chromaticity (CIE 1931)

Color coordinates measured at the center point of LCD

Note 7: Measured at the center area of the panel when all the input terminals of LCD panel are electrically opened.

9.Interface

9.1. LCM PIN Definition

NO	Symbol	Function	I/O
1	LEDK	Cathode of LED backlight	P
2	LEDA	Anode of LED backlight.	P
3	IM0	Note 1	I
4	IM1	Note 1	I
5	IM2	Note 1	I
6	RESET	System reset pin.	I
7	NC(VS)	No Connection (Vrtical Sync signal) Note 2)	I
8	NC(HS)	No Connection (Horizontal Sync signal ; Note 2)	I
9	NC(DCLK)	No Connection (Pixel clock signal; Note 2)	I
10	NC(DE)	No Connection (Data Enable; Note 2)	I
11-16	DB17-12	Data bus (R5~R0; RGB-18bit Pixel; Note 2)	I
17-22	DB11-6	Data bus (G5~G0; RGB-18bit Pixel; Note 2)	I
23-28	DB5-0	Data bus (R5~G0; RGB-18bit Pixel; Note 2)	I
29	NC (SDA)	Connection (serial data input/output pin)	I
30	RD	Read strobe signal. Read out data when RDX is Low.	I
31	WR (SCL)	Write data when WRX is Low.(serial clock input pin)	I
32	D/C	register select	I
33	CS (NCS)	Chip select signal (serial chip select input pin)	I
34	IOVCC	Power supply (TYP:1.8V/2.8V).	P
35	VCI	Power supply(TYP:2.8V).	P
36	GND	Ground	P
37	NC	No connection	
38	NC	No connection	
39	NC	No connection	
40	NC	No connection	

Note 1:

IM2	IM1	IM0	MPU Interface	GRAM
0	0	0	8080 MCU 18-bit bus	D[17:0]
0	1	0	8080 MCU 16-bit bus	D[15:0]
0	1	1	8080 MCU 8-bit bus	D[7:0]
1	0	1	3-Line SPI	SDA,SCL,NCS
1	0	1	RGB interface+3-SPI	D[17:0] (RGB-18bit/Pixel) D[15:0] (RGB-16bit/Pixel)

Note 2:

This module suggests function is for 8080 MCU mode, if this module wants change to use RGB Interface mode, please setting external pin IM [2:0] as 101 (3-SPI Initial code setting RGB-18bit/Pixel or RGB-16bit/Pixel),and reference the **7.5. RGB Interface Selection**

9.2. CTP PIN Definition

Pin	Symbol	Function	Remark
1	VSS	Connect to system ground.	
2	VDDT	Power Supply : +3.3V	
3	SCL	I2C clock input	
4	NC	No connect	
5	SDA	I2C data input and output	
6	NC	No connect	
7	RST	External Reset, Low is active	
8	NC	No connect	
9	INT	External interrupt to the host	
10	VSS	Connect to system ground.	

10. Block Diagram

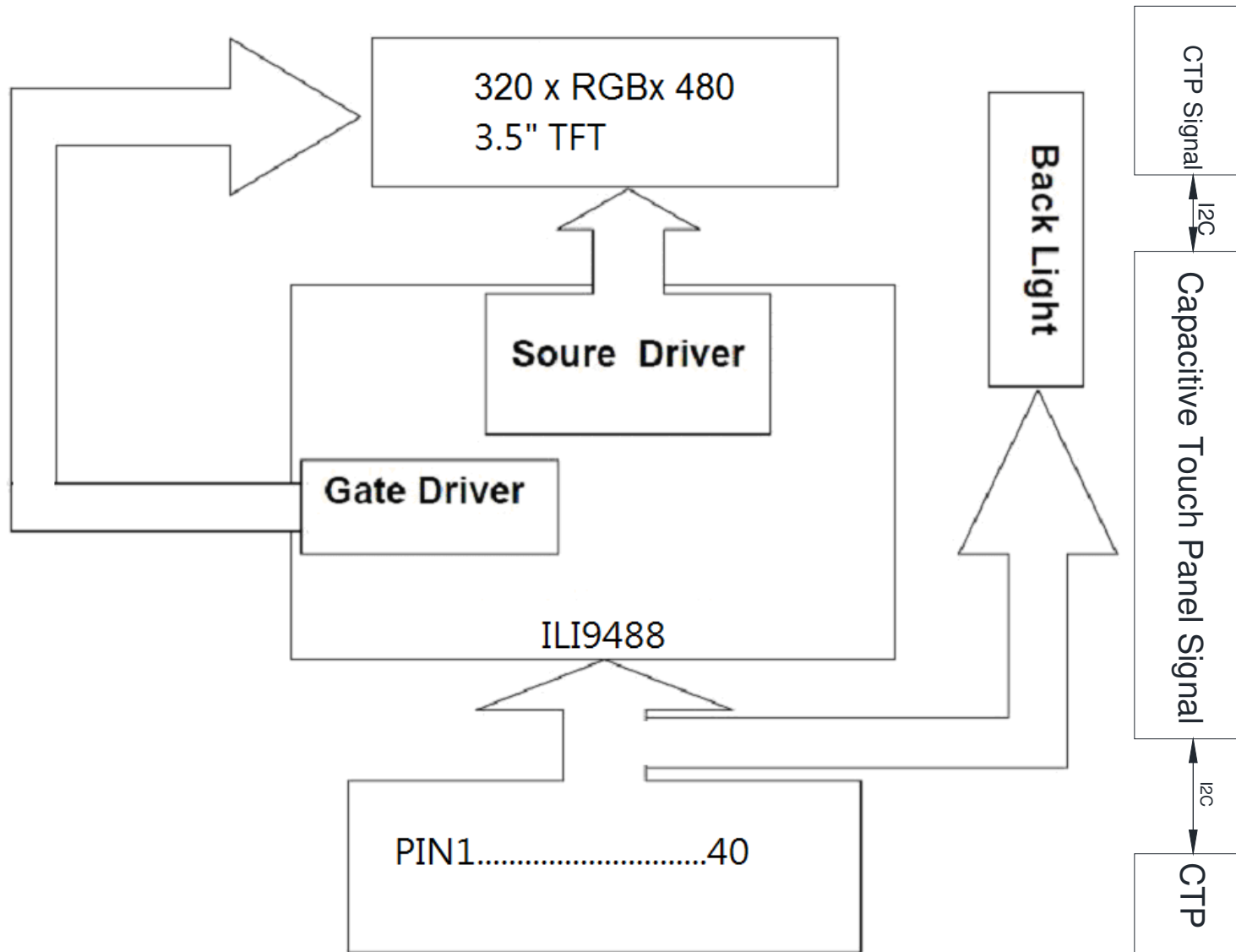

11. Reliability

Content of Reliability Test (Wide temperature, -20°C~70°C)

Environmental Test			
Test Item	Content of Test	Test Condition	Note
High Temperature storage	Endurance test applying the high storage temperature for a long time.	80°C 96hrs	2
Low Temperature storage	Endurance test applying the low storage temperature for a long time.	-30°C 96hrs	1,2
High Temperature Operation	Endurance test applying the electric stress (Voltage & Current) and the thermal stress to the element for a long time.	70°C 96hrs	—
Low Temperature Operation	Endurance test applying the electric stress under low temperature for a long time.	-20°C 96hrs	1
High Temperature/ Humidity Operation	The module should be allowed to stand at 40°C, 90%RH max	40°C, 90%RH 96hrs	1,2
Thermal shock resistance	The sample should be allowed stand the following 10 cycles of operation <div style="text-align: center;"> <p style="margin: 0;">-20°C 25°C 70°C</p> <p style="margin: 0;">30min 5min 30min</p> <p style="margin: 0;">1 cycle</p> </div>	-20°C/70°C 10 cycles	—
Vibration test	Endurance test applying the vibration during transportation and using.	Total fixed amplitude : 1.5mm Vibration Frequency : 10~55Hz One cycle 60 seconds to 3 directions of X,Y,Z for Each 15 minutes	3
Static electricity test	Endurance test applying the electric stress to the terminal.	VS=±600V(contact) ,±800v(air), RS=330Ω CS=150pF 10 times	—

Note1: No dew condensation to be observed.

Note2: The function test shall be conducted after 4 hours storage at the normal Temperature and humidity after remove from the test chamber.

Note3: The packing have to including into the vibration testing.

12.Touch Panel Information12.1.

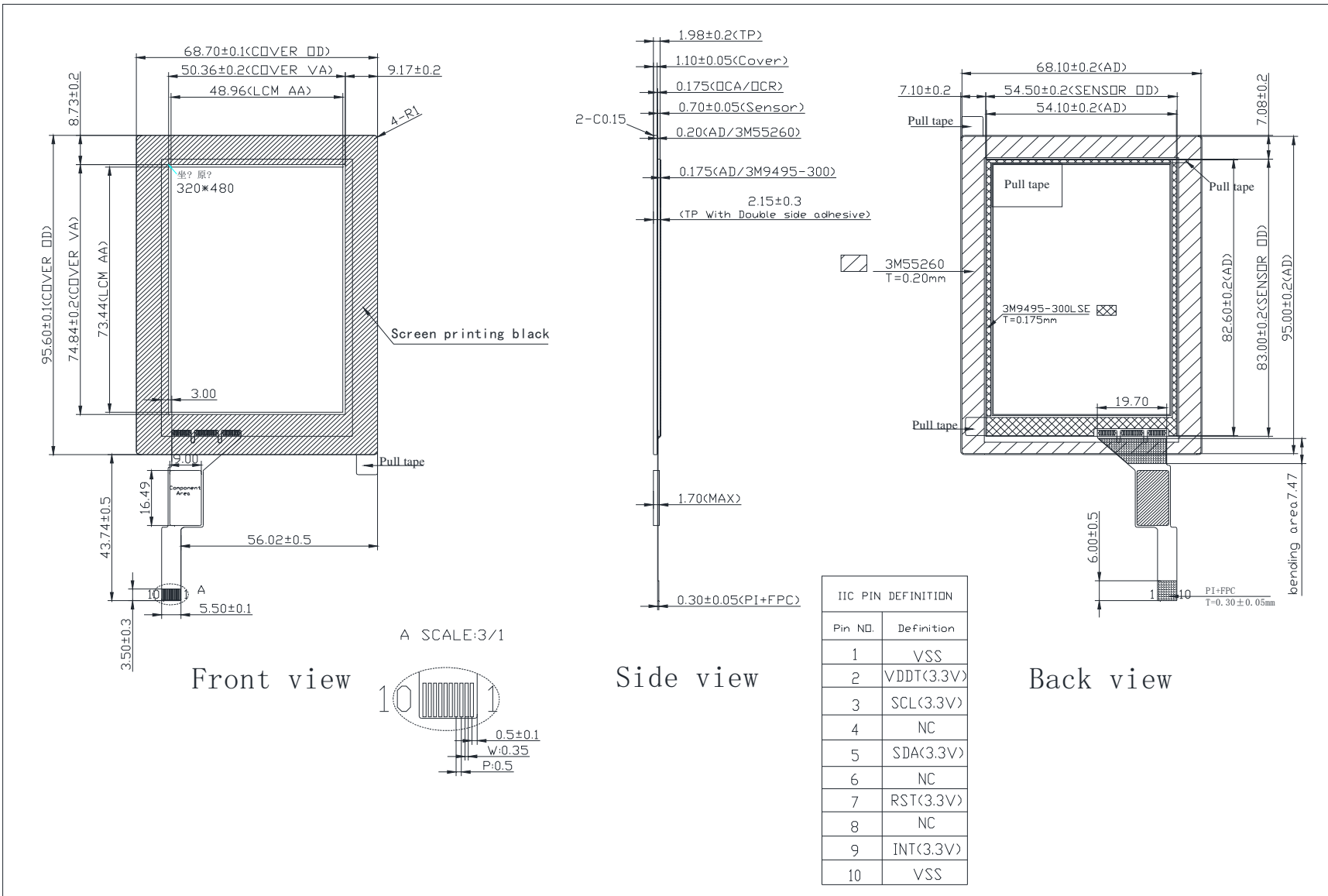

13. Contour Drawing

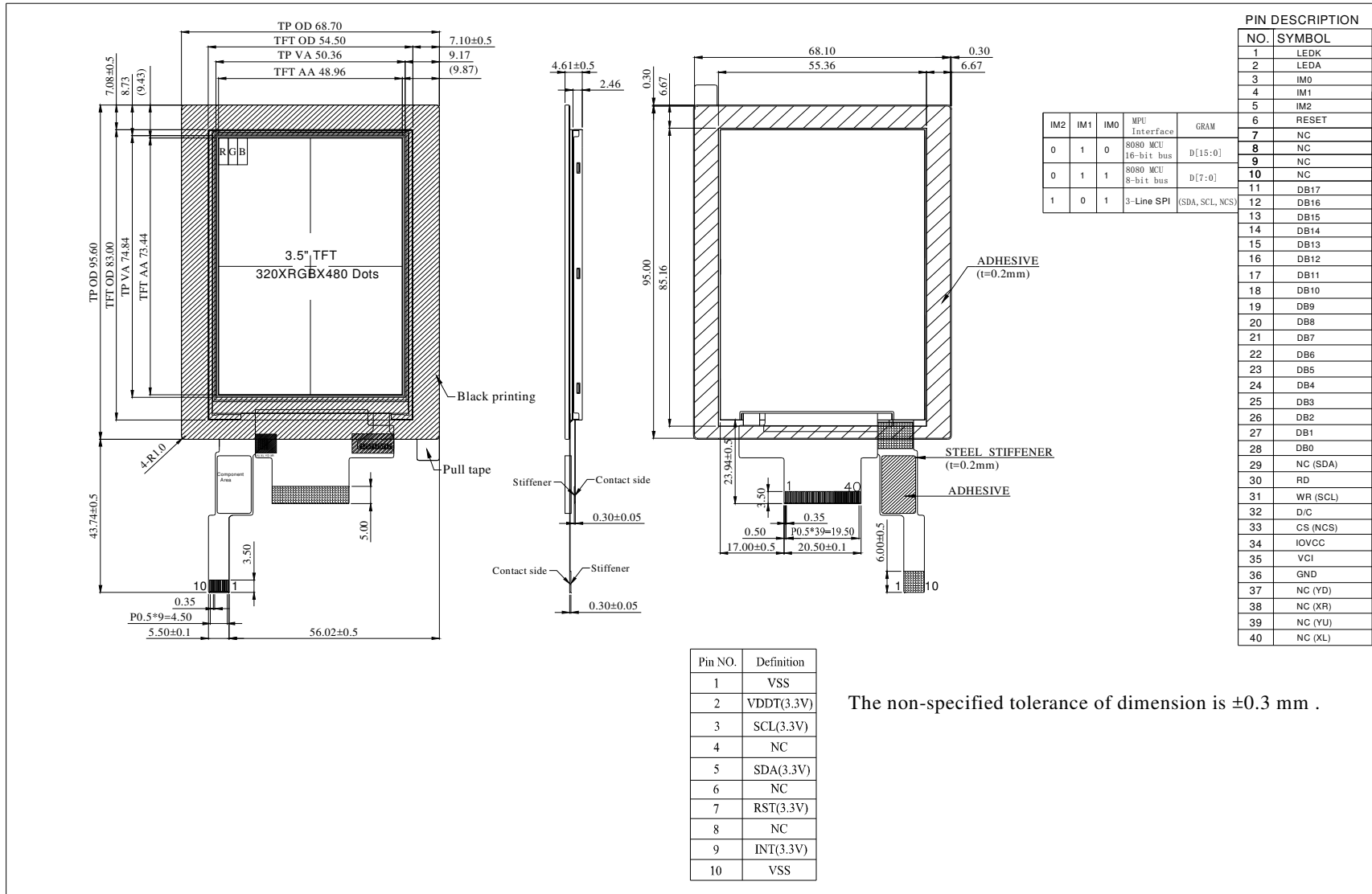

IM2	IM1	IMO	MPU Interface	GRAM
0	1	0	8080 MCU 16-bit bus	D[15:0]
0	1	1	8080 MCU 8-bit bus	D[7:0]
1	0	1	3-Line SPI	(SDA, SCL, NCS)

PIN DESCRIPTION	
NO.	SYMBOL
1	LEDK
2	LEDA
3	IM0
4	IM1
5	IM2
6	RESET
7	NC
8	NC
9	NC
10	NC
11	DB17
12	DB16
13	DB15
14	DB14
15	DB13
16	DB12
17	DB11
18	DB10
19	DB9
20	DB8
21	DB7
22	DB6
23	DB5
24	DB4
25	DB3
26	DB2
27	DB1
28	DB0
29	NC (SDA)
30	RD
31	WR (SCL)
32	D/C
33	CS (NCS)
34	I0VCC
35	VCI
36	GND
37	NC (YD)
38	NC (XR)
39	NC (YU)
40	NC (XL)

Pin NO.	Definition
1	VSS
2	VDDT(3.3V)
3	SCL(3.3V)
4	NC
5	SDA(3.3V)
6	NC
7	RST(3.3V)
8	NC
9	INT(3.3V)
10	VSS

The non-specified tolerance of dimension is ±0.3 mm .



1、Panel Specification :

- 1. Panel Type : Pass NG , _____
- 2. View Direction : Pass NG , _____
- 3. Numbers of Dots : Pass NG , _____
- 4. View Area : Pass NG , _____
- 5. Active Area : Pass NG , _____
- 6. Operating Temperature : Pass NG , _____
- 7. Storage Temperature : Pass NG , _____
- 8. Others : _____

2、Mechanical Specification :

- 1. PCB Size : Pass NG , _____
- 2. Frame Size : Pass NG , _____
- 3. Material of Frame : Pass NG , _____
- 4. Connector Position : Pass NG , _____
- 5. Fix Hole Position : Pass NG , _____
- 6. Backlight Position : Pass NG , _____
- 7. Thickness of PCB : Pass NG , _____
- 8. Height of Frame to PCB : Pass NG , _____
- 9. Height of Module : Pass NG , _____
- 10. Others : Pass NG , _____

3、Relative Hole Size :

- 1. Pitch of Connector : Pass NG , _____
- 2. Hole size of Connector : Pass NG , _____
- 3. Mounting Hole size : Pass NG , _____
- 4. Mounting Hole Type : Pass NG , _____
- 5. Others : Pass NG , _____

4、Backlight Specification :

- 1. B/L Type : Pass NG , _____
- 2. B/L Color : Pass NG , _____
- 3. B/L Driving Voltage (Reference for LED Type) : Pass NG , _____
- 4. B/L Driving Current : Pass NG , _____
- 5. Brightness of B/L : Pass NG , _____
- 6. B/L Solder Method : Pass NG , _____
- 7. Others : Pass NG , _____

>> **Go to page 2** <<



Winstar Module Number : _____

Page: 2

5、Electronic Characteristics of Module :

- | | | | |
|------------------------------|-------------------------------|-------------------------------|-------|
| 1. Input Voltage : | <input type="checkbox"/> Pass | <input type="checkbox"/> NG , | _____ |
| 2. Supply Current : | <input type="checkbox"/> Pass | <input type="checkbox"/> NG , | _____ |
| 3. Driving Voltage for LCD : | <input type="checkbox"/> Pass | <input type="checkbox"/> NG , | _____ |
| 4. Contrast for LCD : | <input type="checkbox"/> Pass | <input type="checkbox"/> NG , | _____ |
| 5. B/L Driving Method : | <input type="checkbox"/> Pass | <input type="checkbox"/> NG , | _____ |
| 6. Negative Voltage Output : | <input type="checkbox"/> Pass | <input type="checkbox"/> NG , | _____ |
| 7. Interface Function : | <input type="checkbox"/> Pass | <input type="checkbox"/> NG , | _____ |
| 8. LCD Uniformity : | <input type="checkbox"/> Pass | <input type="checkbox"/> NG , | _____ |
| 9. ESD test : | <input type="checkbox"/> Pass | <input type="checkbox"/> NG , | _____ |
| 10. Others : | <input type="checkbox"/> Pass | <input type="checkbox"/> NG , | _____ |

6、Summary :

Sales signature : _____

Customer Signature : _____

Date : / / _____