



產品規格 / 承認書

PRODUCT SPECIFICATION / APPROVAL SHEET

客戶
CUSTOMER:

元山型號
Y.S. TECH MODEL NO.:

XYW12038012BSS-S-5

客戶型號
CUSTOMER MODEL NO.:



本承認書內容若貴公司確認無誤，
懇請於下方承認欄內簽章寄回。

Please confirm your acceptance of this
approval sheet by return fax.

承認欄

CONFIRMATION SIGNATURE

元山科技工業股份有限公司
電子熱傳事業部 / Y.S. TECH
電子熱傳事業部

YEN SUN TECHNOLOGY
CORPORATION

高雄市仁武區鳳仁路三二九號 (814)
No.329 Feng Ren Road, Ren Wu Dist,
Kaohsiung, Taiwan ROC 814
Tel: 886-7-3713588 Fax: 886-7-3719643
E-mail: ystech@ystech.com.tw
URL: www.ystech.com.tw

SPEC No.	RS1207048
Issue Date	07/19/12
Edition	0 版
Revised Date	MM/DD/YY

APPROVED	CHECKED	DRAWN
許志聰	蔡子文	張錦華

產品規格 / 承認書

PRODUCT SPECIFICATION / APPROVAL SHEET

A. 一般規格 (General Specification)

項目 (Item)		規格 / 條件 (Specification / Condition)	
01	型號 (Part No.)	XYW12038012BSS-S-5	
02	外型尺寸 (Outline Dimension)	120 X 120 X 38 mm	
03	額定電壓 (Rated Voltage)	DC 12.0 V	
04	操作電壓 (Operating Voltage)	DC 7.0 V ~ DC 13.2 V	
05	起動電壓 (Starting Voltage)	DC 7.0 V	
06	額定電流 (Rated Current)	3.20 A	+ 10% - 20%
07	額定功率 (Rated Power Consumption)	38.40 W	
08	轉速 (Rotational Speed)	9500 R.P.M.	± 10%
09	最大風量 (Max. Airflow)	282.9	CFM (ft ³ /min)
		8.008	m ³ /min
10	最大靜壓 (Max. Static Pressure)	1.662	in-H ₂ O
		42.2	mm-H ₂ O
11	音量位準 (Noise Level)	71.2	dB(A)
12	壽命預估 (Life Expectancy)	60000	hrs at 40°C
13	極數 (No. of Pole)	4	極 (Poles)
14	迴轉方向 (Rotational Direction)	逆時針 (Counter-Clockwise)	

B. 電氣規格 (Electrical Specification)

項目 (Item)		規格 / 條件 (Specification / Condition)	
01	扇葉鎖住保護 (Locked Rotor Protection)	○	安規條件。(Safety Condition)
		○	1.額定電壓鎖住1秒,自動斷電。 (Auto power off after locked at rated voltage for 1 sec.) 2.自動斷電後,2至6秒自動嘗試啟動。 (After auto power off, circuit attempt to restart in 2 to 6 sec.)
02	極性保護 (Polarity Protection)	○	Vcc與GND反接時,不導通。 (Open circuit when Vcc & GND are exchanged)
		○	Vcc與GND反接時,5秒內迴路不燒燬(Circuit won't be burned within 5 seconds when Vcc & GND are exchanged)
03	絕緣阻抗 (Insulation Resistance)	10 MΩ/ 裸線與外框間測量, 500 VDC/min. (10 MΩ/ Between unshielded wire and frame at 500 VDC/min)	
04	絕緣耐壓 (Dielectric Strength)	5 mA Max. / 導線與外框間測量, 500 VAC/min. (5 mA Max. / Measured b/w lead wire (+) and frame at 500 VAC/min)	

C. 主要材料/零件規格 (Main Materials / Parts Specification)

材料/零件 (Materials / Parts)		規格 (Specification)
01	塑膠材料 / 扇葉、外框、絕緣套 (Plastic Material/Blade, Housing, Bobbin)	a. UL 94V-0 b. P.B.T. + 30% GF Black
02	軸承 (Bearing)	雙滾珠軸承(Two Ball Bearing)
03	導線 (Lead Wire)- G. P.	Red (+), Black (-): UL 1007 \ 24 AWG Yellow (FG): UL 1007 \ 24 AWG
04	端子 (Connector)	N / A

D. 安規規格 (Safety Approvals)

安規(Safety)	UL	CUL	TUV
安規編號(File No.)	E223068	E223068	PENDING
安規承認電流 3.5 A + 10% (Approved current is 3.5 A with tolerance of 10%)			

E. 環境測試 (Environmental Specification)

項目 (Item)	規格/條件 (Specification / Condition)
01 運轉溫/溼度範圍 (Operating Temp. Range)	溫度 / Temperature : -10 °C - 70 °C
	溼度 / Humidity : 15 % - 90 % RH (Frost Eliminated)
02 保存溫/溼度範圍 (Storage Temp. Range)	溫度 / Temperature : -20 °C - 75 °C
	溼度 / Humidity : 15 % - 90 % RH (Frost Eliminated)

F. 商標 (Label Marking)

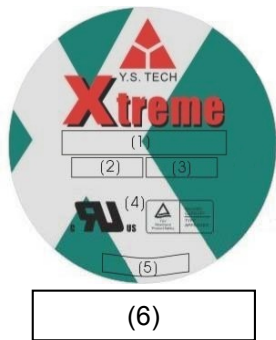

(Top Frame Side)

(1)	型號 (Model No.)
(2)	額定電壓 (Rated Voltage)
(3)	安規電流 (Safety Current)
(4)	安規 (Safety Approvals)
(5)	產地 (Location)
(6)	附碼 (Appendix Code)

G. 噪音量測條件 (Noise Measure Condition)

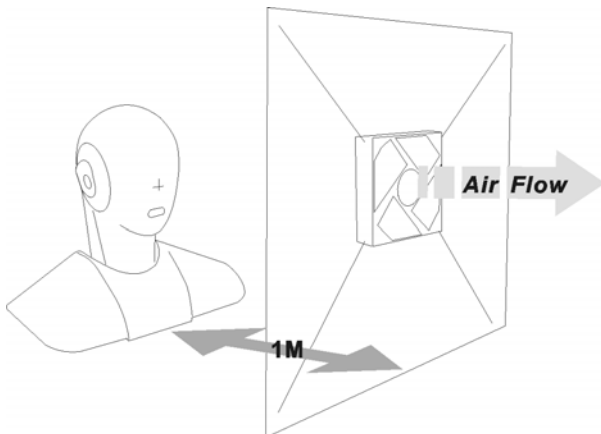

量測系統 (Measurement Systems) :
1.ANECHOIC Room Noise Measurement System.
2.Digital Head Measurement System, 16-bits version.
3.SQlab III, Mobile Multichannel Analysis System.
4.Specifications:ISO 3744, ISO 3745, ISO 7779, CNS 8753, JIS 8346
5.Background Noise: < 17dB(A)

H. 外觀尺寸圖 (Outline Dimension)

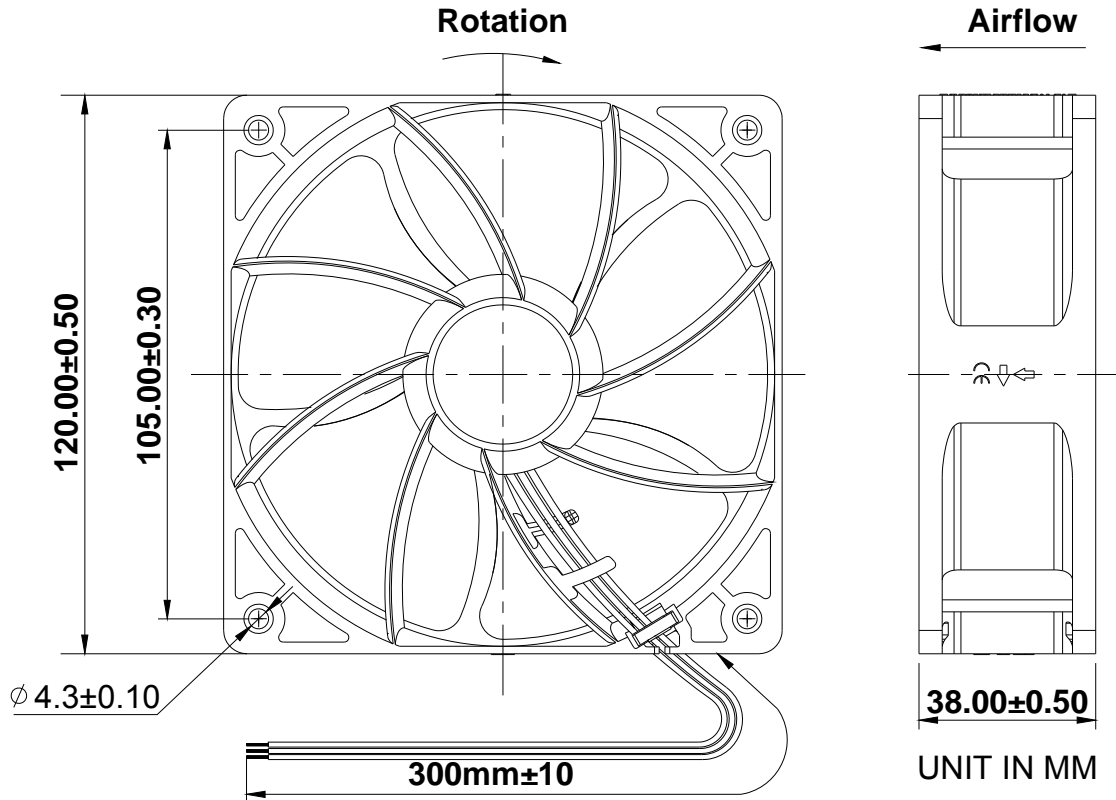

I: 訊號控制系統(Sensor Circuit System)

Speed Sensor / Tachometer (FG/F)

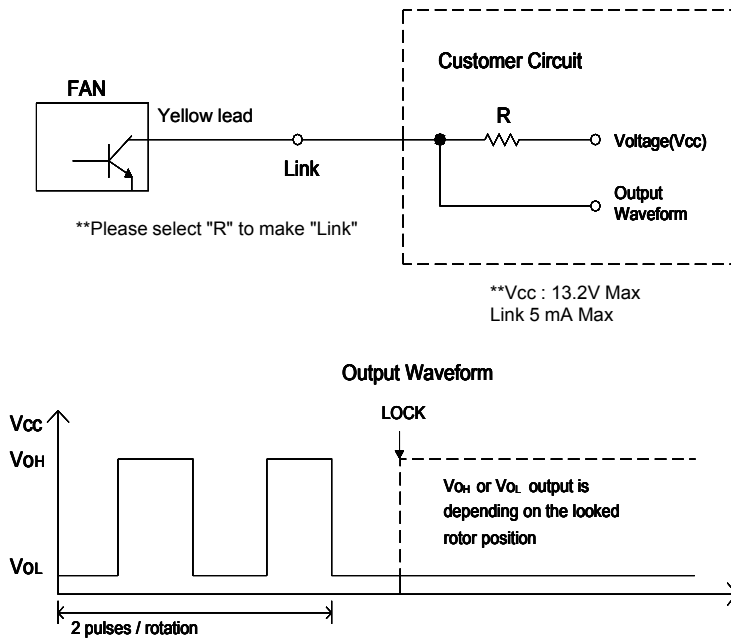

REMARKS

1. All specifications are measured after 5 min. rotating. Y.S. Tech will not assume responsibility for performance of products if application condition is outside of parameters stated forth in the specification.
2. A written request should be submitted to Y.S. Tech prior to approval if abnormality and deviation from this specification is required.
3. Please be cautious when fan is being exercised or handled. Applying pressure to the impeller, handling the fan by lead wire, or dropping the fans to the production platform is resulting in damage.
4. The operating voltage and temperature were defined after fan rotating continually at rated voltage.
5. If fan was stocked at an ambient temperature under 5°C and over 24 hrs. Please stock fans to an ambient temperature over 20°C and remained over 24 hrs before using. All specifications include abnormal noise have to be measured after 30 minute running.
6. Noise Level is different from abnormal noise. Please send abnormal samples to Y.S. TECH to analyze. We estimate noise level by equation when noise level is lower than background noise (17dB).
7. Starting Voltage was defined on power on/off condition. Rotational speed was defined on full speed by its rated value.
8. The correct polarity, Positive(+) and Negative(-), has to be clearly identified before connecting the fan to the power. Be aware of the connection with reverse polarity may lead to damage since no effective protection can be introduced against such errors.
9. L10 of Life test is a deductive value under statistical method and it is different from product warranty.
10. All general specifications and quality values are measured under condition of free air and fan vertical set up. Y.S. TECH highly suggests to practic a test when fan apply to a special application.
11. With exception of suitability of some particular designs, any failure and problems regarding safety of the product caused by the introduction of powder, droplets of water or encroachment of insert in the hub are not guaranteed.
12. It is important to consider safety when using the fans. A suitable fan guard should be fitted to the fan to guard against any potential for personal injury.
13. Y.S. Tech fans are not well suited for corrosive environments. This includes liquids, gases, or matters.
14. Except for the feature of the Lock Rotor Protection specifically stated, this feature is not applied to all fans. Y.S. Tech highly suggests not to stop the impellers of the working fans such interruption will cause adverse effect.
15. Fans are to be stored in a dry/cool place. High levels of humidity are harmful to products.
16. Please be cautious. Y.S. Tech is not responsible for any excess resonance, vibration and subsequent noise caused by incorrect mounting of fans.
17. Take necessary precaution handling fans when in operation. Fingre guards are recommended to prevent personal injury.
18. All test environments are conducted under the condition of relative(ambient) temperature and humidity at 25°C, 65%. The test result stated above is effective only for unique fan performance.
19. To avoid any unstable power, an "over 4.7 μ F" capacitor has definitely be connected to fan externally whatever multiple fans are applied in parallel.
20. The above conditions are examples of extreme application. However they are very important and should receive top priority.

Yen Sun Technology Corporation

History of Specification

Project Name: XYW12038012BSS-S-5

The above mentioned product relates to the following documents:

Document / -Number	Version / Index	Date / Released (Month/Date/Year)	Changed
RS1207048	Ver : 0	07/19/12	

If any of fan performance or characters will be changed, this history document has to be real-time updated as well.